

PULSACOIL STAINLESS

MAINS PRESSURE HOT WATER THERMAL STORE
SPECIFICALLY DESIGNED FOR APARTMENTS



INSTRUCTION MANUAL DESIGN, INSTALLATION & SERVICING

ONE NAME. EVERY SOLUTION.



Section	Page
DESIGN	
Description	3
Model Selection	6
PRODUCT SPECIFICATION	
Components	7
Technical Specification Table	8
TRANSPORTATION	
Lifting and Handling	9
INSTALLATION	
Domestic Hot Water	10
Boiler Store Charging	15
Electrical Installation Work	19
HEADER TANK INSTALLATION	21
COMMISSIONING	
Commissioning and checks	24
Do's & Don'ts	25
SERVICING AND MAINTENANCE	
Short Parts List	26
Annual Service	27
Changing Components	28
Fault Finding	29
APPENDIX	
Appendix A - Flow Regulators	34
Appendix B - Corrosion & Scale Prevention	35
Terms & Conditions	36
Benchmark Checklist	38
Benchmark Service Record	39

The Gledhill PulsaCoil range complies with the HWA Specification for hot water only thermal storage products. The principle was developed in conjunction with British Gas. This product is manufactured under an ISO 9001:2008 Quality System audited by BSI.



Benchmark places responsibilities on both manufacturers and installers. The purpose is to ensure that customers are provided with the correct equipment for their needs, that it is installed, commissioned and serviced in accordance with the manufacturers instructions by competent persons and that it meets the requirements of the appropriate Building Regulations. The Benchmark Checklist can be used to demonstrate compliance with Building Regulations and should be provided to the customer for future reference.

Installers are required to carry out installation, commissioning and servicing work in accordance with the Benchmark Code of Practice which is available from the Heating and Hot Water Industry Council who manage and promote the Scheme. Visit www.centralheating.co.uk for more information.

For further information on the HWA Charter Statement, please refer to the HWA website hotwater.org.uk.

Any water distribution system/installation must comply with the relevant recommendations of the current version of the Regulations and British Standards listed below:-

Gas Safety (Installation and use) Regulations 1998
Building Regulations
Water Supply (Water Fittings) Regulations 1999
Manual Handling Operations Regulations

British Standards

BS EN 806:1-5: BS EN 8558:2011
Requirements for Electrical Installations BS7671:2008 and A2:2013 18th Edition

Most new building work will require the relevant building control body to be notified prior to the building work commencing. This will not be required if the work is carried out under a self certification scheme or if the work is not notifiable. Full details of the self certification schemes and work that is not notifiable can be obtained from page 9 of Approved Document G, available from www.planningportal.gov.uk.

A suitably competent trades person must install the PulsaCoil and carry out any subsequent maintenance/repairs. The manufacturer's notes must not be taken as overriding statutory obligations.

The Domestic Building Services Compliance Guide 2013 defines, one of the fixed building services, as any part of or controls associated with fixed systems for domestic hot water. All fixed building services, including their controls, should be commissioned by testing and adjustment to ensure that they use no more fuel and power than is reasonable in the circumstances. Where commissioning is required, if it is completed by a person registered with a competent person scheme, the commissioning notice will be supplied by that person, otherwise the person carrying out the work must notify the relevant building control body, that commissioning has taken place in accordance with the Domestic Heating Compliance Guide. The building control body will then be able to issue a completion certificate. This applies to England, for other jurisdictions in the UK, it may be necessary to consult their own building regulations and guidance.

The PulsaCoil is not intended for use by persons (including children) with reduced physical, sensory or mental capabilities, or lack of experience or knowledge, unless they have been given supervision or instruction concerning use of the appliance by a person responsible for their safety.

Children should be supervised to ensure that they do not play with the appliance.

The information in this manual is provided to assist generally in the selection of equipment. The responsibility for the selection and specification of the equipment must however remain that of the customer and any Designers or Consultants concerned with the design and installation.

Please Note: We do not therefore accept any responsibility for matters of design, selection or specification or for the effectiveness of an installation containing one of our products unless we have been specifically requested to do so.

All goods are sold subject to our Conditions of Sale, which are set out at the rear of this manual.

In the interest of continuously improving the PulsaCoil range, Gledhill Building Products Ltd reserve the right to modify the product without notice, and in these circumstances this document, which is accurate at the time of printing, should be disregarded. It will however be updated as soon as possible after the change has occurred.

The Environment

This product has been manufactured using many recyclable materials, including the approved HCFC/CFC free polyurethane foam insulation. At the end of its useful life, it should be disposed of at a Local Authority Recycling Centre, to maximise the products full environmental benefits.

DESIGN

PulsaCoil products are vented cylinders, so there is no requirement for a pressure and temperature relief valve to be fitted to them.

This is a key benefit of a thermal store over an unvented cylinder. This enables greater flexibility of location in the building, as there is no requirement to install discharge pipework with a constant fall to an outside wall, or upgrade the soil and vent pipework to be able to withstand high temperature discharges.

Standby Consumption

This unit uses minimal power in stand by mode, and can be turned off if required.

Immersion Heaters

All PulsaCoils are supplied with two immersion heaters 3kW 250v AC, complete with a thermostat set at 75°C and an overheat thermostat set at 90°C, which will require resetting if operated.

The bottom immersion provides the main heat source for the unit, generally from an off peak supply.

The top immersion heater's purpose is to provide a backup heat source if the bottom immersion or the off peak supply is out of operation, commonly activated via a boost button facility. Please note that this back up facility will only provide limited input for the domestic hot water requirement.

Heat Loss

The heat losses from thermal stores should not be directly compared with heat losses from unvented or vented cylinders because they are treated differently in SAP. This is because the unvented and vented cylinders are tested at 65°C and the thermal store at 75°C.

Feed and Expansion Cistern

The feed and expansion cistern must be located above the thermal store.

For hot water only PulsaCoil models, the feed and expansion tank must be above the top of the thermal store.

The maximum working pressure of the thermal store is 1 bar. This means that the feed and expansion tank can be located up to 10 metres above the base of the thermal store.

The 150 and 180 litre units are supplied with a circular header tank. Please follow the instructions on the label provided for filling the unit. This header tank is not suitable for auto filling using a ball valve. Manual filling using a temporary hose connection fitted with a double check valve is possible. The 210 unit is supplied with a square header tank which should be mounted on a suitable shelf.

The standard preferred arrangement of the top up cistern is for the cistern to be manually filled from a temporary hose connection fitted with a double check valve.

Cupboard Requirements

The appliance is designed to be installed in an airing/cylinder cupboard and the relevant minimum dimensions are provided in the Technical Specification table of this manual.

Because of the ease of installation we recommend that the cupboard construction is completed and painted before installation of the appliance. The cupboard door can be fitted after installation.

If the unit needs to be stored prior to installation it should be stored upright in a dry environment and on a level base/floor.

Installation and maintenance access is needed to the front of the appliance and above the Top up cistern. See the Technical Specification table in this manual for further details.

The installation base is not used extra space may be needed to allow connection to the pipework and the whole of the base area should be continuously supported on a material which will not easily deteriorate if exposed to moisture.

The floor of the cupboard needs to be level and even and capable of supporting the weight of the appliance when full. Details of the weight when full is provided in the Technical Specification table of this manual.

The appliance is designed to operate as quietly as practicable. However, some noise (from pumps etc) is inevitable when hot water is being used. This will be most noticeable if the cupboards are located adjacent to bedrooms, on bulkheads, or at the mid span of a suspended floor. Some noise may also be experienced from the immersion heaters as the store approaches its design temperature.

Cupboard temperatures will normally be slightly higher than in a conventional system and the design of the cupboard and door will need to take this into account. No ventilation is normally required to the cupboard.

Left Hand

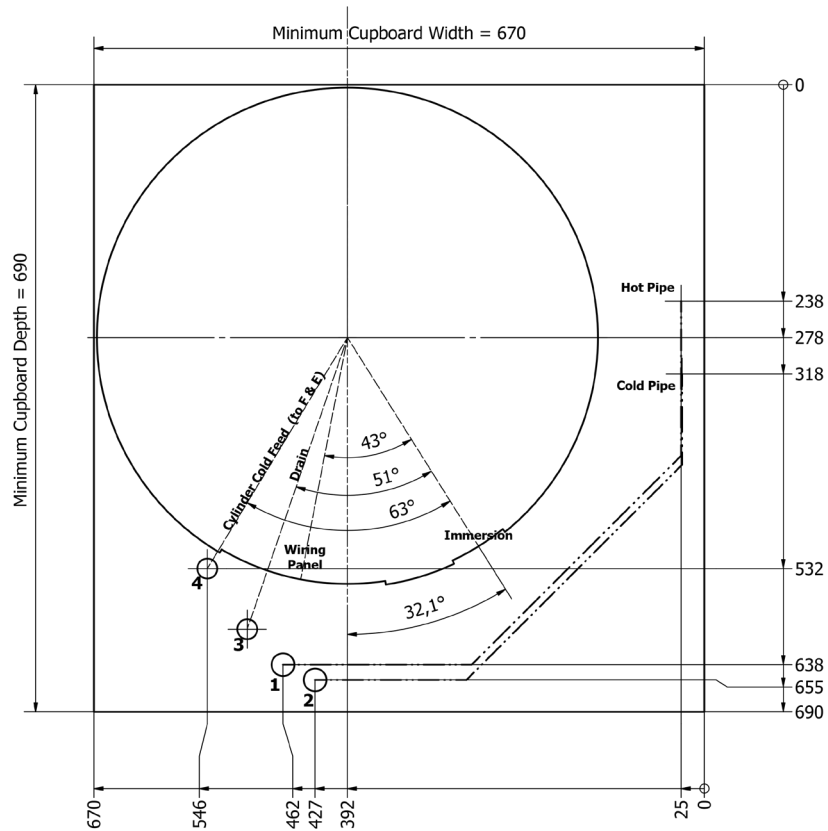
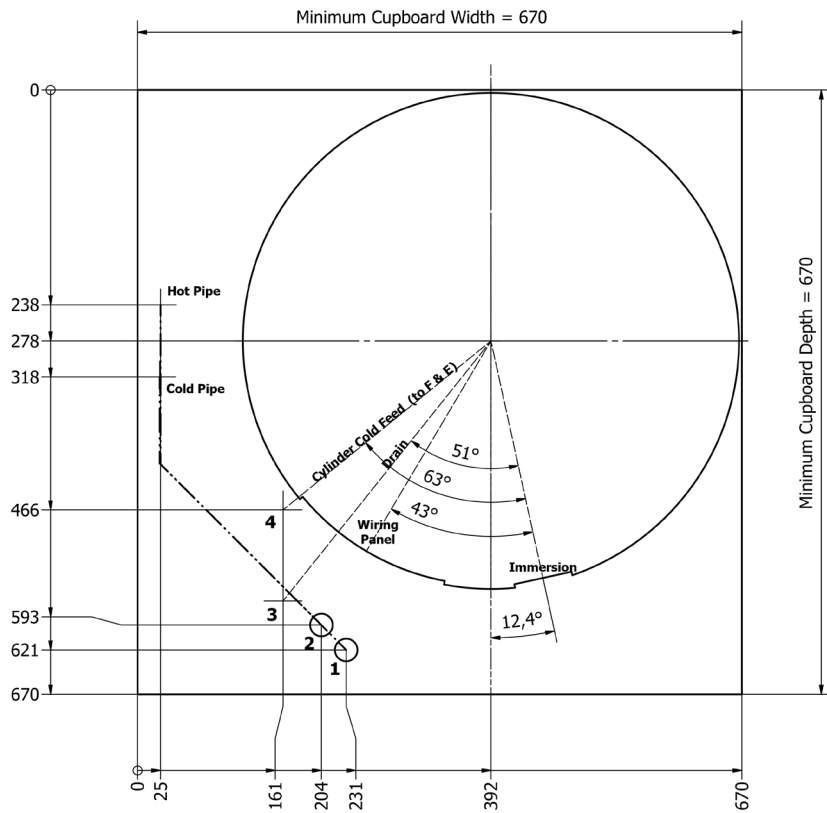

DESIGN

Right Hand

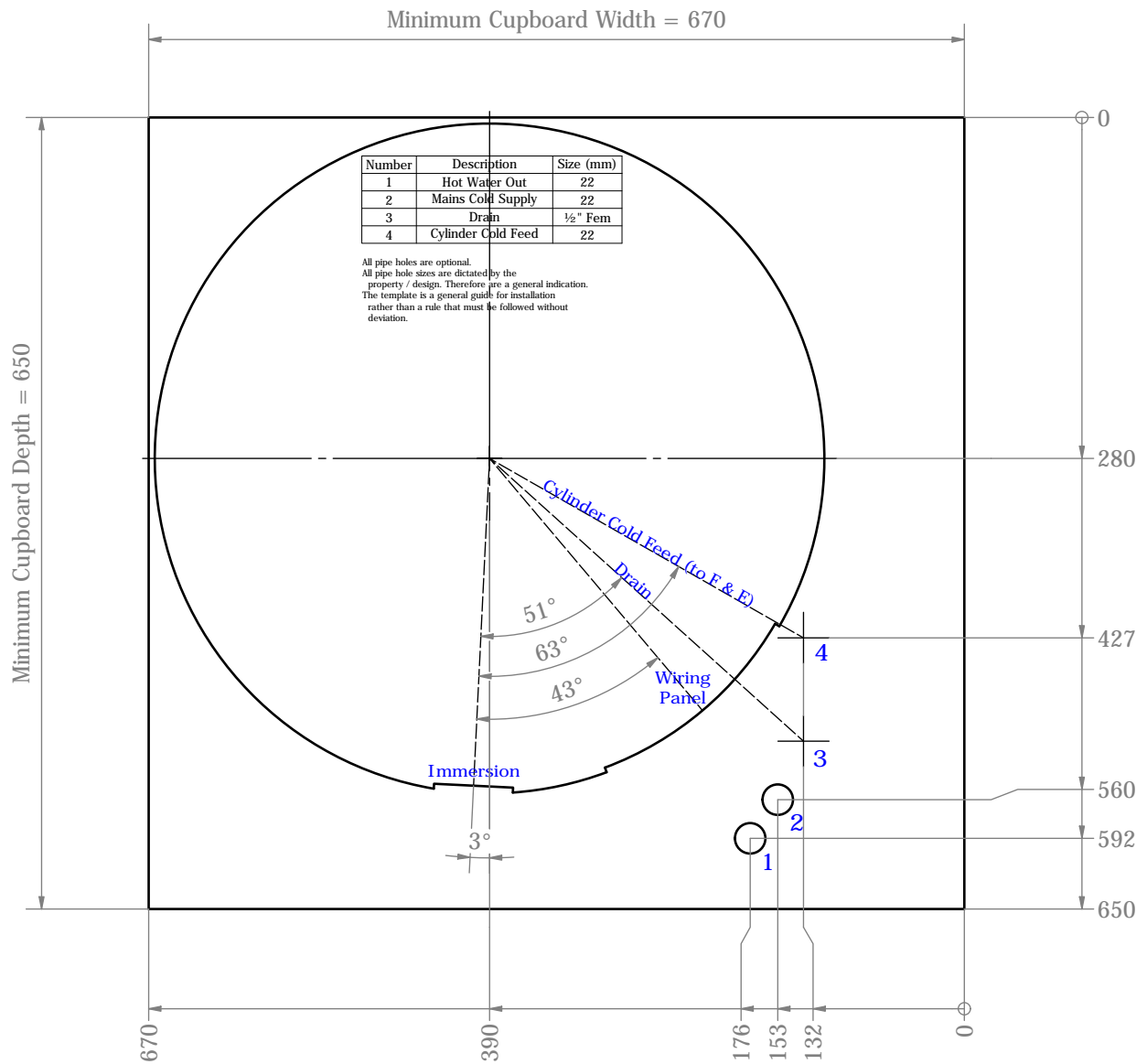

Model Selection Guide PulsaCoil				
Dwelling Type				
Bedroom	1-2	2-3	2-3	2-4
Bathroom	1 or	1	1	2
En-suite shower rooms	1	1	2	1
Model size required - Economy 7 tariff	PCCST150**	PCCST150**	PCCST180**	PCCST210**
Model size required - Economy 10 tariff	PCCST150**	PCCST150**	PCCST150**	PCCST180**

Notes:-

1. Circular Plastic header tank with lid supplied with the 150 & 180 units. Oblong header tank supplied with the 210 unit.
2. A minimum of 40°C temperature rise is achieved at 12.6 litres/min flow rate and assume that recommended pressures and adequate flow are available at the appliance. The actual flow rate from the appliance is automatically regulated to a maximum of 15 litres/min.
3. The domestic hot water temperature is not user adjustable.

SPECIFICATION

The PulsaCoil is a hot water thermal store. It is intended to be used in conjunction with either 3kW immersion heaters or an open vented heat only boiler. The boiler should be plumbed directly to the thermal store. The immersions and boilers purpose is to keep the thermal store hot.

Domestic hot water is generated instantaneously by the PulsaCoil domestic hot water assembly. It is supplied to the taps at mains pressure and at 55°C.

Please see the drawing below for connections, location size and type.

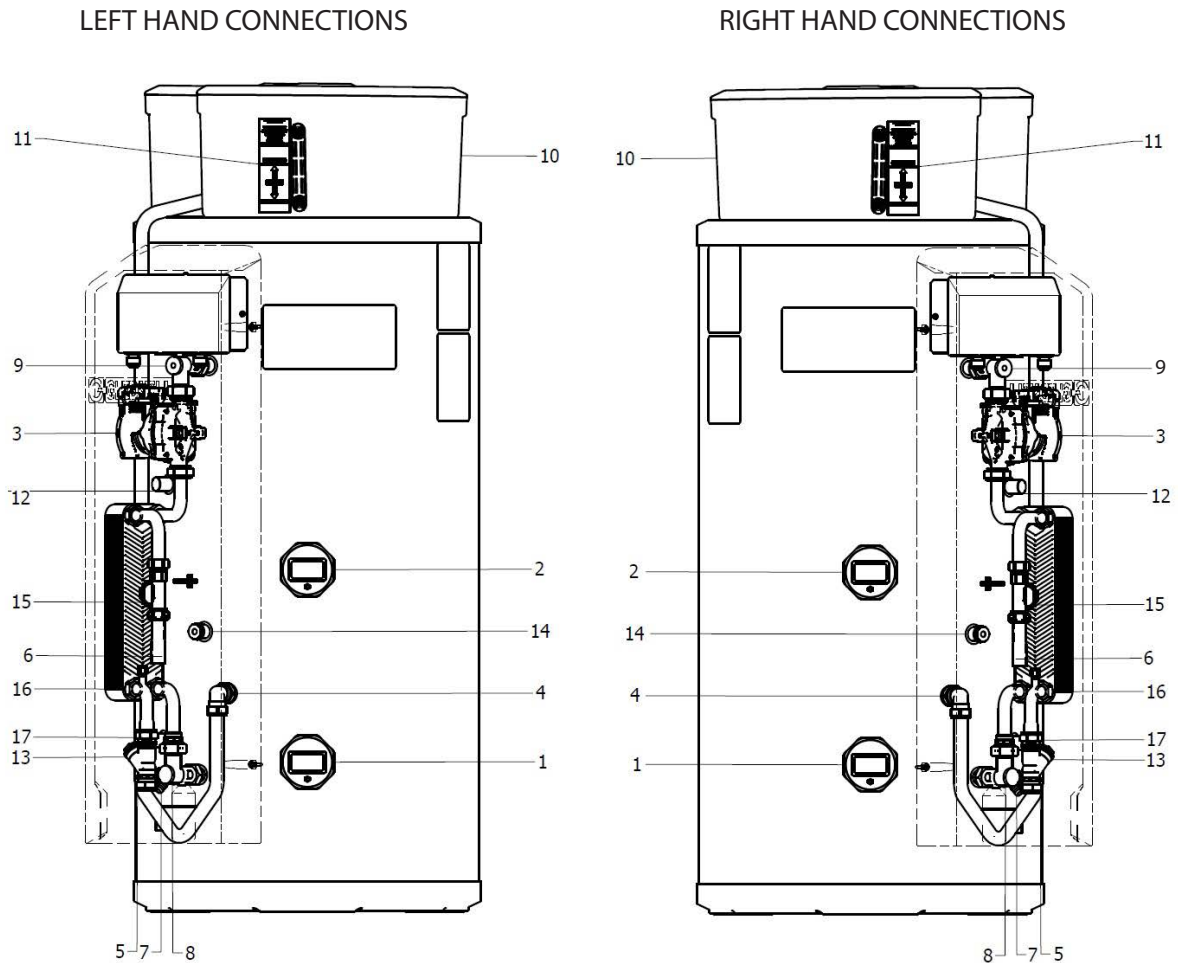

Standard Equipment

- | | | | |
|---|---|----|--|
| 1 | 3kW Bottom (Off-Peak) immersion heater (1H_1) | 9 | Flow from store to PHE (no check valve) |
| 2 | 3kW Top (On-Peak) immersion heater (1H_2) | 10 | Feed and expansion tank |
| 3 | PHE pump | 11 | Vent pipe (inside F&E slot) |
| 4 | Cold feed (22mm) | 12 | Boiler flow |
| 5 | CW inlet (22mm compression) | 13 | Boiler return |
| 6 | HW outlet (22mm) | 14 | Control thermostat pocket |
| 7 | Drain (supplied in the header tank kit) | 15 | Flow sensor |
| 8 | Return from PHE to store (inc check valve) | 16 | Domestic hot water PHE 24 plate |
| | | 17 | Flow regulator (at top of inline strainer) |
| | | 18 | Component insulation (not shown) |

Kit Supplied With Unit (not fitted - see Page 21)

- | | |
|---|--|
| A | Tank Lid |
| B | Circular feed and expansion tank |
| C | Water level Sight glass |
| D | Header tank filling instruction label |
| F | 22mm tank connector |
| G | Bent cold feed pipe |
| H | Vent Pipe Grommet |
| J | Vent pipe |
| K | Two 22mm compression vent pipe couplings |

Note: If the feed and expansion tank is sited at a higher level additional components will be required.

SELECTION

Technical Specification PulsaCoil Stainless				
Product Stock Code		PCCST150LH ^{5,6}	PCCST180LH ^{5,6}	PCCST210LH ^{5,6}
Energy efficiency class		C	C	C
Off-peak available		Y	Y	Y
Heat loss	watts	47	55	62
	kWh/24hr	1.48	1.78	2.08
Height	mm	1112	1300	1488
Diameter ⁴	mm	550	550	550
Min cupboard height ¹	mm	1582	1770	1958
Min cupboard width ²	mm	670	670	670
Min cupboard depth	mm	650	650	650
Weight (empty)	kg	35	39	47
Weight (full)	kg	186	220	258
Thermal store volume	litres	151	181	211
Domestic hot water volume (above 40 degrees)	litres	138	154	196
Maximum DHW pressure ³	bar	5	5	5

Where heated by a boiler	
Boiler Power (kW)	Recovery time in mins based on 40 degree temperature rise
15	30.6
18	25.5
21	21.8
24	19.1
28	16.4

Notes:-

1. The height stated in the table is to the top of the unit. Add 470mm to this height, which should allow for a 220mm high header tank and room for servicing. This will need to be increased by 125mm if the automatic fill method is chosen.
2. The top up cistern can be remotely sited above the PulsaCoil.
3. Full thermal store volume reheated from 35°C to 75°C.
4. 400mm is required to extract the immersion heater and 600mm for personnel access.
5. The scale model variant should be ordered where water hardness levels are between 200 and 300 ppm (mg/l). If this option is required, please order PCCST150LHSCALE, PCCST180LHSCALE or PCCST210LHSCALE.
6. Right hand orientation products may be ordered as specials. The L in the code changes to an R. The product codes are PCCST150RH, PCCST180RH and PCCST210RH; and for the scale versions PCCST150RHSCALE, PCCST180RHSCALE and PCCST210RHSCALE.

TRANSPORT

Preparation / Placing The Appliance in Position

The appliance should be handled carefully to avoid damage and the recommended method is shown above.

Note: Although the above guidance is provided any manual handling/lifting operations will need to comply with the requirements of the Manual Handling Operations Regulations issued by the H.S.E.

The appliance can be moved using a sack truck on the rear face although care should be taken and the route should be even.

In apartment buildings containing a number of storeys we would recommend that the appliances are moved vertically in a mechanical lift.

If it is proposed to use a crane expert advice should be obtained regarding the need for slings, lifting beams etc.

Before installation the site requirements should be checked and confirmed as acceptable.

Manual Handling Of The Appliance

Manual handling means any transporting or supporting of a load (including lifting, putting down, pushing, pulling, carrying or moving) by hand or bodily force.

Scope

This assessment will cover the largest unit within each product range.

For specific weights and dimensions please refer to technical data section.

Main Hazards

Vision may not be clear due to the size of the products. Adopting an incorrect method of lifting may cause injury, attempting to lift these products will require help from others. (Team lifts)

Manual Lifting Procedure

The lift, key factors in safe lifting are:

- a. **Balance**
 - b. **Position of back**
 - c. **Positioning of the arms and body**
 - d. **The hold**
 - e. **Taking the lead for team lifts**
- a. **Balance** - Since balance depends essentially upon the position of the feet, they should be apart about hip breadth with one foot advanced giving full balance sideways and forward without tension. In taking up this position, lifting is done by bending at the knees instead of the hips and the muscles that are brought into use are those of the thigh and not the back.
 - b. **Position of back** - Straight - not necessary vertical. The spine must be kept rigid, this coupled with a bent knee position, allows the centre line of gravity of the body to be over the weight so reducing strain.
 - c. **Positioning of arms and body** - The further arms are away from the side, the greater the strain on the shoulders, chest and back. Keep elbows close to the body arms should be straight.

- d. **The hold** - Before lifting ensure you have a good hold.
- e. **Taking the lead for team lifts**- As more than one person is required for these products ensure that one person is taking the lead. **This may be you** so ensure that each person that is helping is made aware of the weight and of the items listed within this assessment. Make sure you and any others helping know the route you intend to take that it is clear of any obstructions. Never jerk the load as this will add a little extra force and can cause severe strain to the arms, back and shoulders. If there are steps involved decide on where you will stop and take a rest period. Move smoothly and in unison taking care to look and listen to others helping with the lift. Where possible use a sack truck to move the product over long flat distances, only lift the products when necessary. If in doubt stop and get more help.

Individual Capability

Individual capability plays an important part in handling these products. Persons above average build and strength will find it easier and should be in good health. Persons below average build and strength may require more rest periods during the handling process.

Pregnant women should not carry out this operation.

Persons who are not in good health should seek medical advice prior to commencing any lifting or manual handling operation.

Residual Risk

Following the guidelines given above will reduce any risk to injury.

All persons carrying out this operation must be fully trained and copies of the specific risk assessment made available for inspection and use in their training process.

Further guidance on Manual Handling can be obtained from the Health and Safety Executive. Manual Handling Operations Regulations 1992 (amended by Health and Safety (Miscellaneous Amendments) Regulations 2002).

INSTALLATION

Hot And Cold Water

An important feature of the PulsaCoil is that hot water can be supplied directly from the mains at conventional flow rates without the need for temperature and pressure relief safety valves or expansion vessels. This is achieved by passing the mains water through a plate heat exchanger. The outlet temperature of the domestic hot water is maintained by a printed circuit control board, which controls the speed of the pump circulating the primary water from the store through the plate heat exchanger.

Pressures

A schematic layout of the hot and cold-water services in a typical small dwelling is shown below. PulsaCoil will operate at mains pressures as low as 1 bar and as high as 5 bar although the recommended range is 2-3 bar dynamic at the appliance.

It is also important to check that all other equipment and components in the hot and cold water system are capable of accepting the mains pressure available to the property. If the mains pressure can rise above 5 bar or the maximum working pressure of any item of equipment or component to be fitted in the system, a pressure limiting (reducing) valve set to 3 bar will be required. If you encounter a situation where the water pressure is adequate but flow rates are poor please contact our technical helpline for details of an effective solution.

Inline Strainer/Flow Regulator

Each PulsaCoil is fitted with a strainer and flow regulator on the cold mains supply connection, restricting to 15 l/pm. If the supply pressure is less than 2 bar or if all taps are provided with flow regulators the flow regulator on the cold inlet should be removed.

Check valve locations

No check valve or similar device should be fitted on the cold-water supply branch to the PulsaCoil.

Water Hardness

The Domestic Building Services Compliance Guide (2013) provides more detailed information on the guidance contained in Approval Documents L1A and L1B, guidance to the Building Regulations. The recommended minimum standards specify that “where the mains water hardness exceeds 200ppm provision should be made to treat the feed water to water heaters and the hot water circuit of combination boilers to reduce the rate of accumulation of lime scale”.

To comply with this requirement the hardness of the mains water should be checked by the installer and if necessary, the scale model variant should be ordered, for hardness levels between 200 and 300 ppm (mg/l). Alternatively, the inline scale inhibitor XB043, can be ordered which is fitted in the cold water pipework prior to the DHW PHE.

Where the water is very hard i.e. 300ppm (mg/l) and above a polyphosphate type, inhibitor should be fitted by the installer at a suitable point in the cold water supply to the appliance.

Water Meter

If a water meter is fitted in the service pipe, it should have a nominal rating to match the maximum hot and cold water peak demands calculated in accordance with BS EN 806:1-5: BS EN 8558:2011. This could be up to 60ltr/min in some properties.

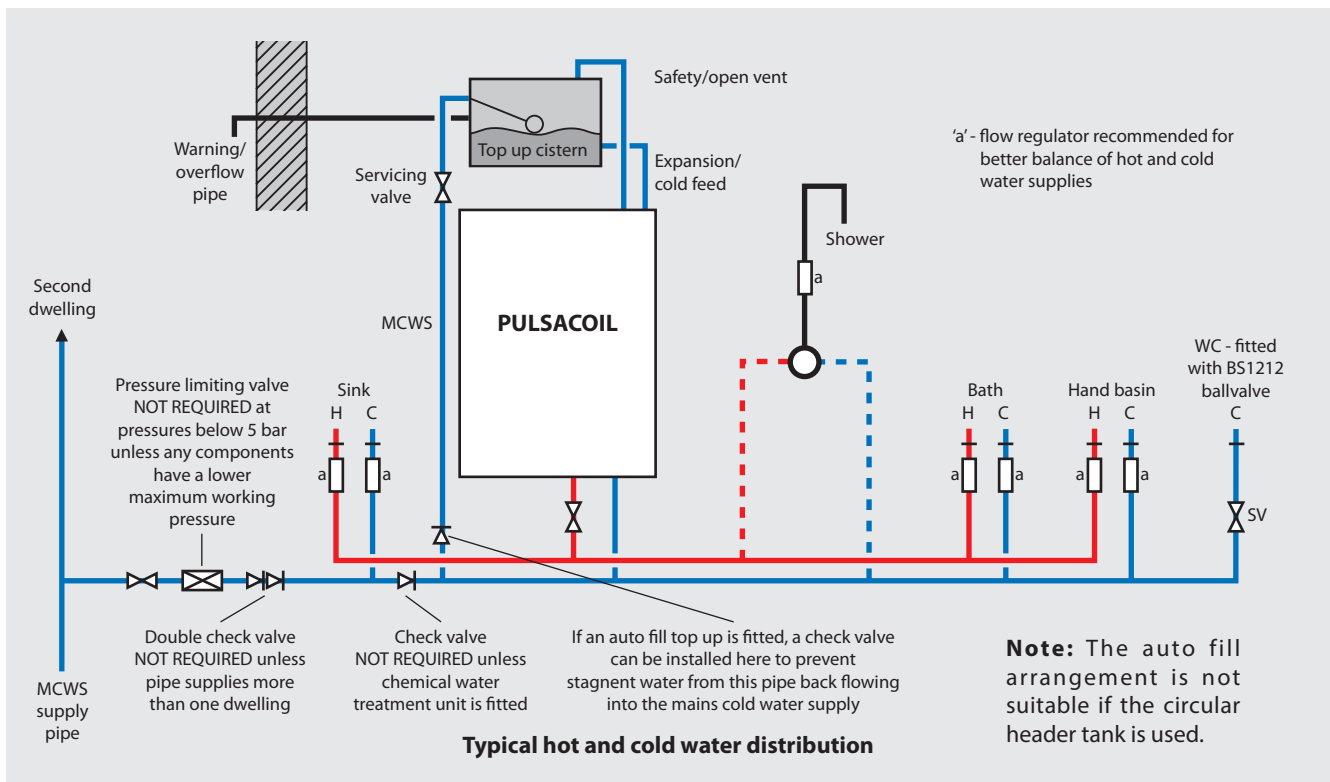

INSTALLATION

Pipe Sizing / Materials / Push Fit

To achieve even distribution of the available supply of hot and cold water, it is important in any mains pressure system, that the piping in a dwelling should be sized in accordance with BS EN 806:1-5: BS EN 8558:2011. This is particularly important in a large property with more than one bathroom.

However, the following rule of thumb guide lines should be adequate for most smaller property types as long as water pressures are within the recommended range.

1. A 15mm copper or equivalent external service may be enough for a small 1 bathroom dwelling (depending upon the flow rate available), but the minimum recommended size for new dwellings is 22mm (25mm MDPE).
2. The internal cold feed from the main incoming stop tap to the PulsaCoil should be run in 22mm pipe. The cold main and hot draw-off should also be run in 22mm as far as the branch to the bath tap.
3. The final branches to the hand basins and sinks should be in 10mm and to the baths and showers in 15mm (1-meter minimum).
4. **We would recommend that best results for a balanced system are achieved by fitting appropriate flow regulators to each hot and cold outlet. This is particularly relevant where the water pressures are above the recommended water pressure range. Details of suitable flow regulators are provided in Appendix A.**

All the recommendations with regard to pipework systems in this manual are generally based on the use of BS/EN Standard copper pipework and fittings.

However, we are happy that plastic pipework systems can be used in place of copper internally as long as the chosen system is recommended for use on domestic hot and cold water systems by the manufacturer and is installed fully in accordance with their recommendations. This is particularly important in relation to use of push fit connections when using the optional flexible hose kits - see installation section of this manual.

It is also essential that if an alternative pipework material/system is chosen the manufacturer confirms that the design criteria of the new system is at least equivalent to the use of BS/EN Standard copper pipework and fittings.

Secondary circulation

If the length of the hot water draw off pipework is excessive and the delivery time will be more than 60 seconds before hot water is available at the tap, you may wish to consider using trace heating to the hot water pipework such as the Raychem HWAT system. Also, a conventional pumped secondary circulation system (shown below) can be used with any model of the PulsaCoil.

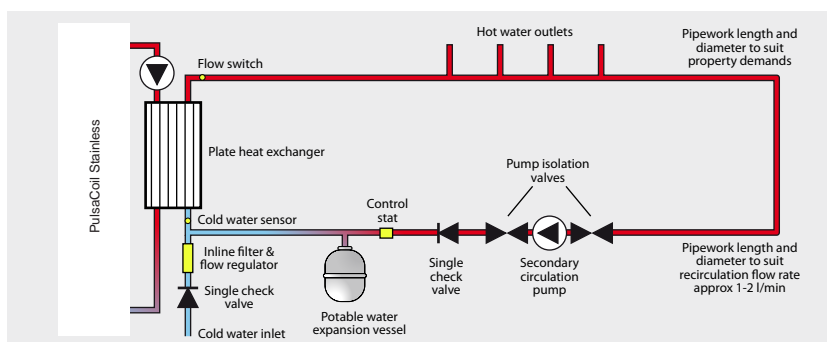

A pipe thermostat is incorporated in the circuitry which cuts the supply to the pump when the water in the return pipe reaches the set temperature. Ensure the hot water temperature is set correctly to avoid excessively hot water at the outlets and long pump run times.

Secondary circulation pipework must be insulated to prevent energy loss in both heated and unheated areas.

Bath Hot Water Temperature

Bath hot water supplies should be limited to a maximum of 48°C using an inline blending valve.

Pipe Separation

It is important that the cold-water pipework is adequately separated/protected from any heating/hot water pipework to ensure that the water remains cold and of drinking water quality.

Tap outlets

Aerated taps are recommended to prevent splashing.

Showers

Any type of shower mixing valve can be used as long as both the hot and cold supplies are mains fed. However, all mains pressure systems are subject to dynamic changes particularly when other hot and cold taps/showers are opened and closed, which will cause changes in the water temperature at mixed water outlets such as showers. For this reason and because these are now no more expensive than a manual shower we strongly recommend the use of thermostatic showers with this appliance. The shower head provided must also be suitable for mains pressure supplies.

However, if it is proposed to use a 'whole body' or similar shower with a number of high flow/pressure outlets please discuss with the Gledhill technical department.

Shower Pipework

The hot water supply to a shower-mixing valve should be fed wherever practical directly from the PulsaCoil or be the first draw off point on the hot circuit. The cold supply to a shower-mixing valve should wherever practical be fed directly from the rising mains via an independent branch. The shower must incorporate or be fitted with the necessary check valves to provide back-siphonage protection in accordance with the Water Regulations.

Bidet Supply

The supply of hot and cold mains water directly to a bidet is permitted provided that it is of the over-rim flushing type and that a type 'A' air gap is incorporated.

INSTALLATION

Domestic Hot Water Controls Wiring

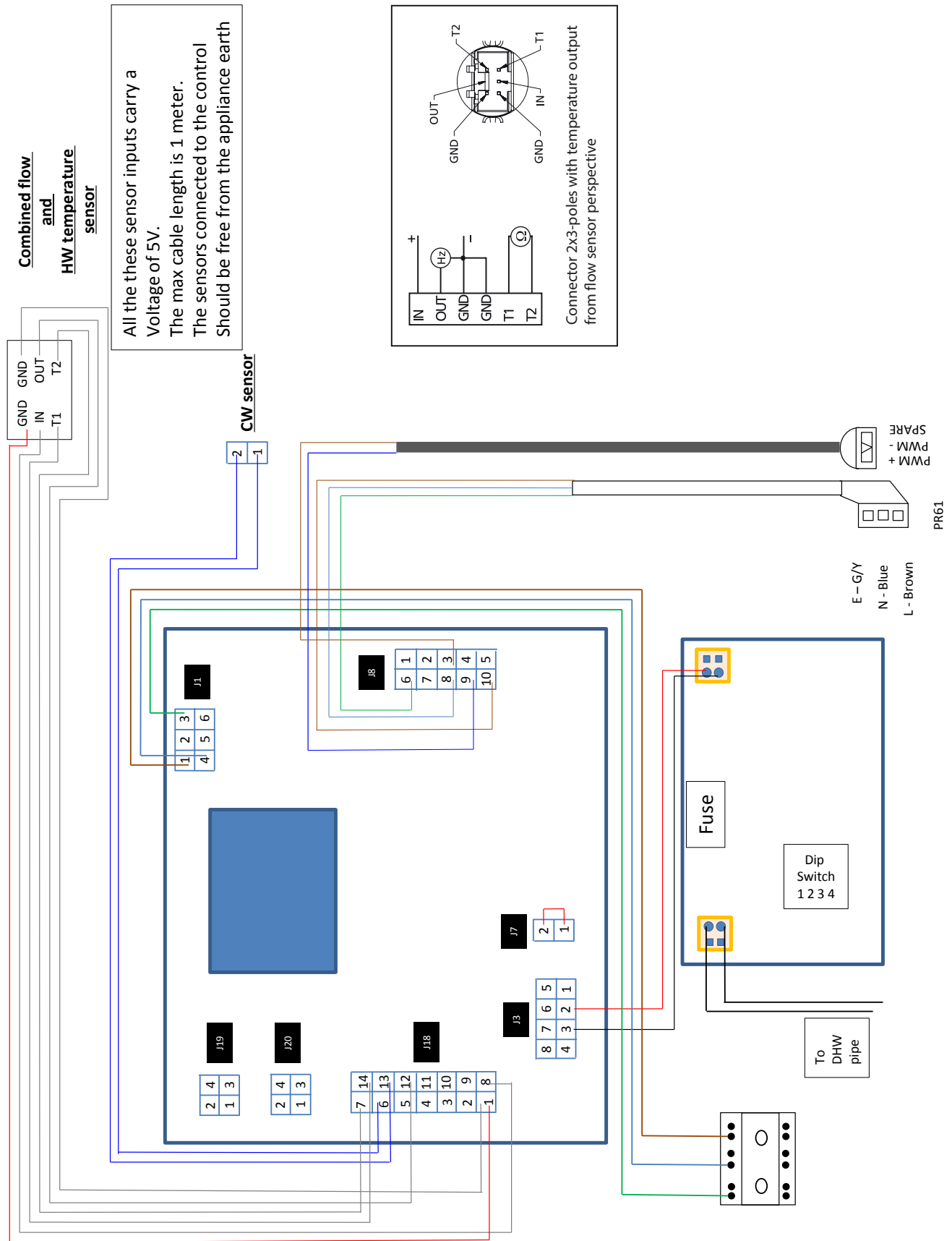

INSTALLATION

Domestic Hot Water Performance Test Flow rates

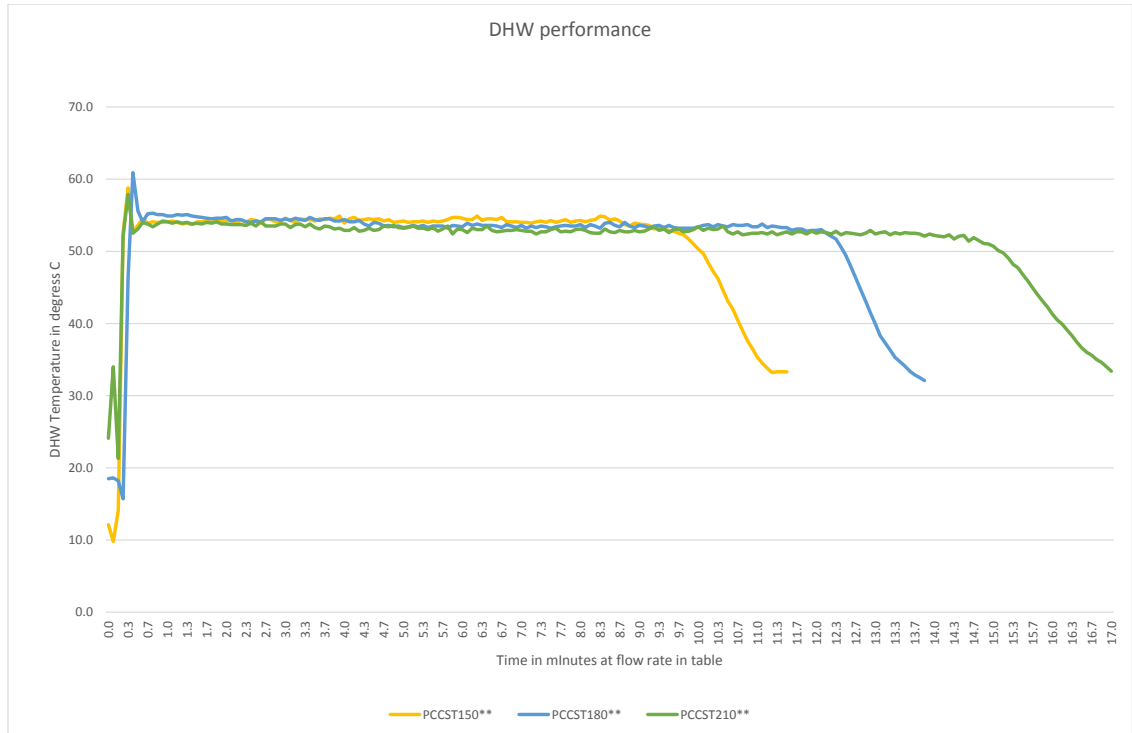

INSTALLATION

Hot water draw off volume VHW-N

Product reference	DHW flow rate		Hot water delivery temperature		Thermal store temperature		HW delivered above 40 degrees C	
	[l/sec]		[°C]		[°C]		[Litres]	
	Target	Actual	Nominal	Actual	Nominal	Actual	Min	Actual
PCCSTMC150	0.21	0.21	55	54	75	75	94	138
PCCSTMC180	0.21	0.21	55	53	75	75	113	154
PCCSTMC210	0.21	0.21	55	55	75	75	131	196

Pressure Flow Characteristics Of The DHW Heat Exchanger

Flow (l/m)	Pressure Drop (bar)
0	0
6.3	0.121516
7.5	0.168105
9.45	0.258502
11.25	0.357679
12.6	0.441755
13.86	0.527598
15	0.611323
15.75	0.669513
16.5	0.730151
18.75	0.926607

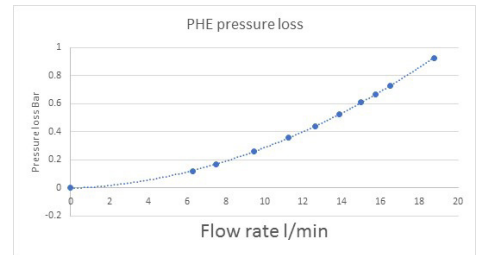

INSTALLATION

LEFT HAND CONNECTIONS

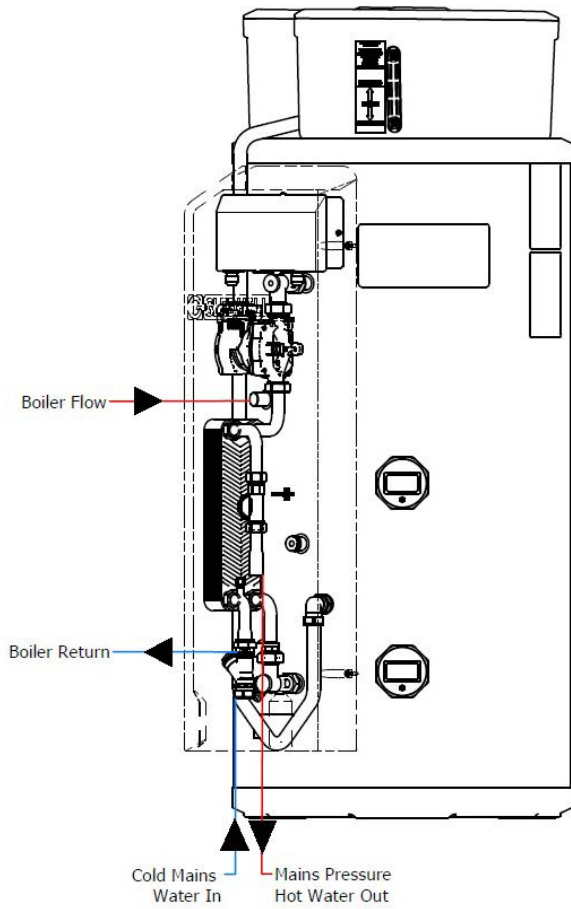

RIGHT HAND CONNECTIONS

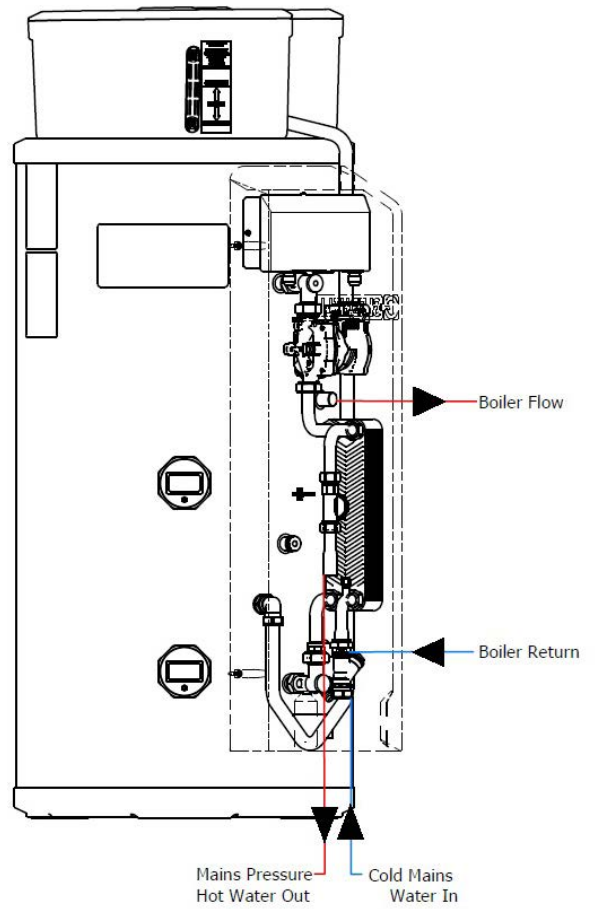

INSTALLATION

Heating System

General – Sealed And Open Vented Heating Systems

The PulsaCoil Stainless is suitable for the open vented system. The thermal store must always be open vented.

No valve should be fitted in the safety open vent and which must be a minimum of 22mm copper pipe or equivalent.

The PulsaCoil Stainless can also be used with condensing or non condensing oil or gas boiler which is capable of delivering hot water at a minimum temperature of 80°C.

The boiler must be set to operate at nominal 82°C flow which usually corresponds to maximum boiler control thermostat setting.

It is recommended that an automatic bypass is fitted to compensate for pressure and hence the flow rate changes in the heating circuit e.g. when the thermostatic radiator valves close. The bypass valve must be set by the installer to suit the system i.e. to provide minimum flow required for the boiler when all TRVs are closed.

Pipe Sizing And Materials – Open Vented Heating Systems

All the recommendations with regard to heating systems in this manual are generally based on BS/EN Standard copper pipework and fittings. However we are happy that plastic pipework system can be used in place of copper as long as long as the: -

- The chosen system is recommended for use in domestic heating systems by the manufacturers and it is installed fully in accordance with their recommendations.
- The design criterion of the plastic system is at least equivalent to the use of BS/En Standard copper pipework and fittings.
- We always recommend the barrier pipe for these systems.
- The circular F & E tank is not suitable for use with an open vented boiler system. It does not have the facility for auto fill and is sized to cater for the thermal store expansion only. The chosen F & E tank must be mounted less than 10m above above the base of the thermal store.

Minimum pipe size for flow and return 22mm.

Open Vented Heating Systems

The PulsaCoil Stainless is equally suitable for 'S' and 'W' plan heating system layouts.

The flow pipe from the boiler should rise continuously up to the vent pipe to facilitate venting. The heating circuit is taken directly from the boiler and is piped in the conventional manner.

If this cistern is used for the central heating, then the water level in the F&E cistern should be at least 250mm above the highest point on the system including the radiators and must be high enough to provide the minimum head required by the boiler being used.

INSTALLATION

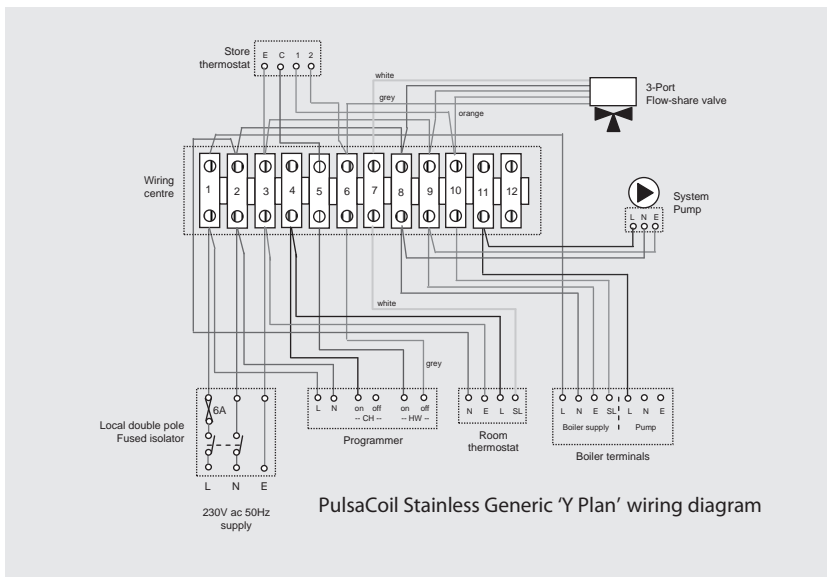

Electrical Wiring

- 1 An electrical supply must be available which is correctly earthed, polarized and in accordance with the latest edition of the IEE requirements for electrical installations BS 7671.
- 2 The electrical mains supply needs to be 230V/50Hz.
- 3 A means for disconnection from the supply mains having a contact separation in all poles that provides full disconnection under over voltage category III conditions must be incorporated in the fixed wiring in accordance with the wiring rules. This shall be located within 1m of the appliance and only serve the appliance.
- 4 The 230Vac 50hz supply to the system wiring centre must be in accordance with the relevant IEE Wiring Regulations on the circuit must be protected by a suitable 5A fuse and a double pole local isolating switch

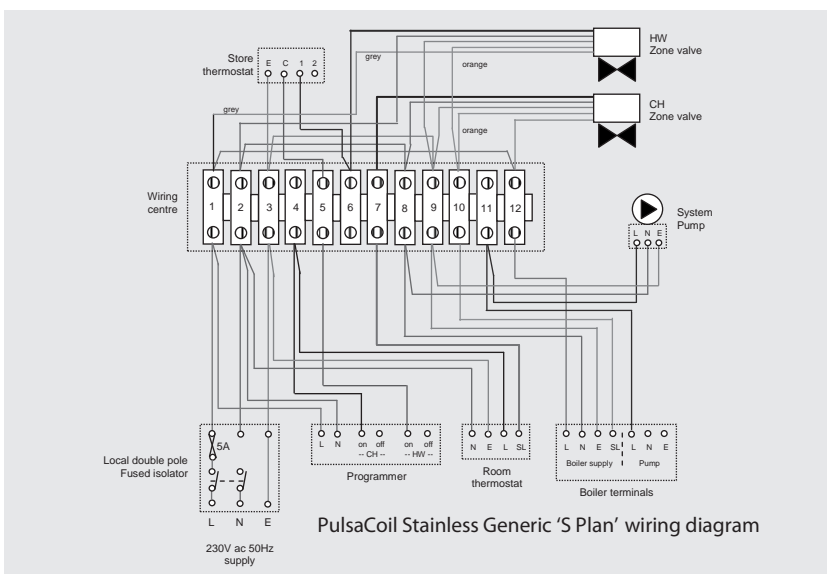

INSTALLATION

Boiler Thermostat Setting

The PulsaCoil may be installed with condensing or non-condensing oil or gas boilers. These boilers should be capable of delivering primary hot water at a minimum temperature of 80°C. To achieve the highest temperature in the thermal store and therefore maximise its performance the maximum boiler control thermostat setting must be selected.

Store Thermostat Setting

The store thermostat should be set at 75°C to achieve the maximum domestic hot water and the temperature set point of 50-55°C. We recommend this is checked during the commissioning procedure due to the tolerances on this type of thermostat.

Electrical Connection - Standard Appliance

The external wiring/connections should be carried out by a competent person to BS7671. The arrangement of the internal wiring is shown on page 14.

All the terminals are suitably labelled.

Note: Do not attempt the electrical work unless you are competent to carry it out to the above standards.

Before commencing check that the power source is in accordance with the Site Requirements section of this manual and ensure that it is isolated as shown in the System Details section.

Run the external wiring from the adjacent isolator through the service slot provided in the base of the appliance.

Clamp the cables in the grips provided and ensure all cables are routed to avoid hot surfaces.

Note: The appliance pipework should be bonded to earth to comply with the IEE Requirements for Electrical Installations BS 7671.

Before switching on the electrical supply check all the factory made terminal connections to ensure they have not become loose during transit.

INSTALLATION

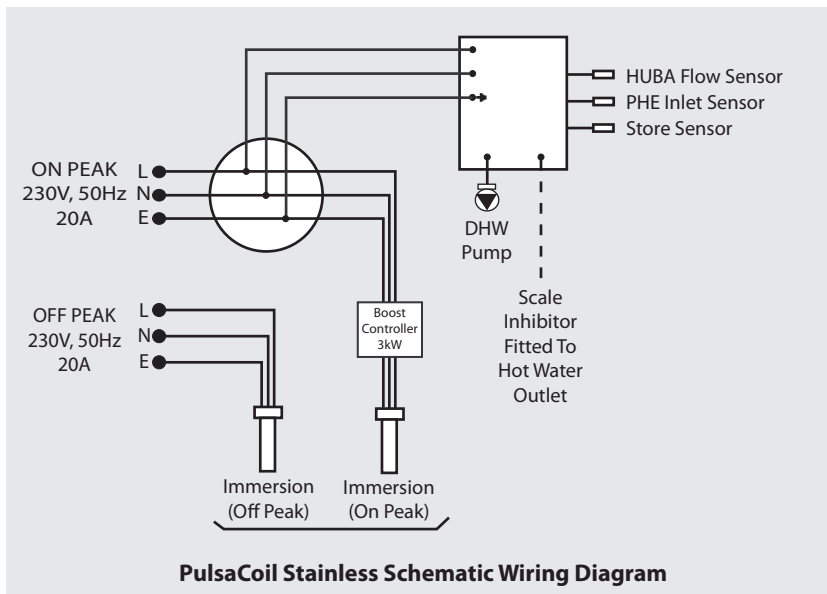

Electrical Installation

The Schematic arrangement of the wiring within the PulsaCoil Stainless is shown above.

The whole of the electrical installation shall be designed and installed by a competent person fully in accordance with the latest edition of the Requirements for Electrical installations BS 7671.

The PulsaCoil Stainless appliance is provided with two side entry 3kW immersion heaters and has been designed to generally operate with an off peak supply.

The lower immersion heater heats the whole of the contents and is normally connected to the off peak supply.

The upper immersion heater is positioned at a level on the PulsaCoil Stainless to heat the top 66 - 111 litres of the store. This is connected to the unrestricted on peak supply and is switched manually by the householder using the button on the boost controller.

The size of the appliance and the need to use the on peak boost facility is reduced if a better off peak tariff can be agreed with the electrical supply company.

The immersion thermostat has two terminals L and N. These should be connected as shown in the diagram below. It has been our experience that crimp terminals make better connections. The immersion heater must be fully earthed using the earth post provided. Each immersion must have a 20 amp double isolator fitted locally to enable servicing.

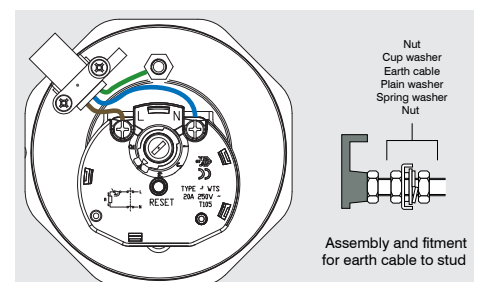
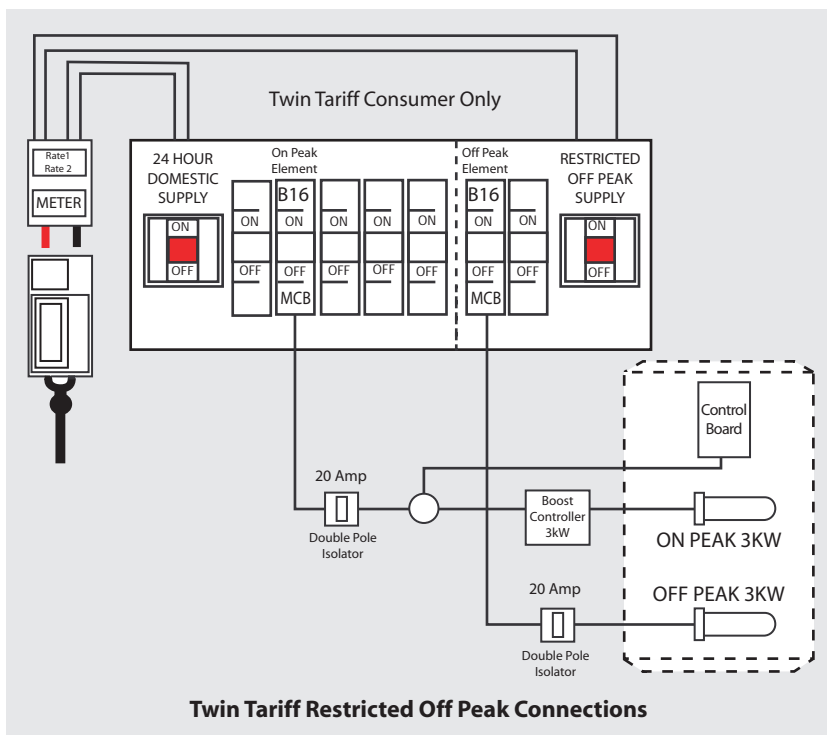

Immersion Heater Wiring
Thermostat Type WTS fitted in the immersions, and are supplied set in position 5.0 at 75°C ± 3°C.

Thermostat manufacturer's part number is WTS22D11JM

The immersion heater thermostat complies with EU directives on Electromagnetic compatibility and radio interference. It is rated at 20 amp 250V AC. It is factory set at 75 degrees for control and 90 degrees for overheat. If the manual overheat thermostat operates, please investigate the cause before pressing the reset button labeled RESET. If there is no apparent fault adjust the control setting down slightly to prevent nuisance tripping.

Danger of electrocution: before making any adjustments to the thermostat isolate the immersion heater from the mains electricity supply at the fuse spur unit.

Wiring The PulsaCoil With A Split Consumer Unit I.e. Separate On And Off Peak Supplies.

Historically this has been the typical supply method and no special wiring arrangements are required.

INSTALLATION

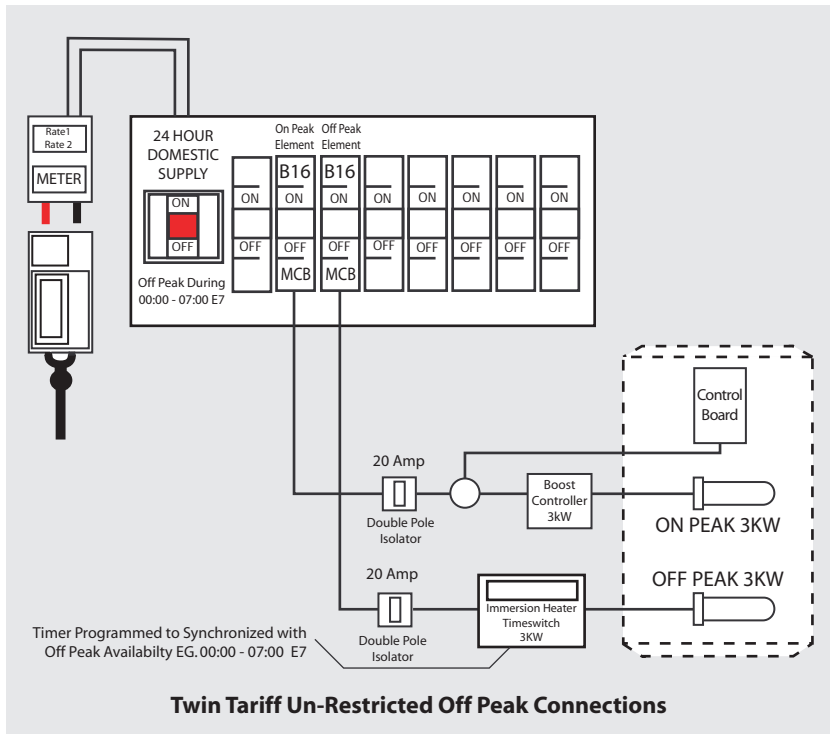

Wiring The PulsaCoil Stainless With Combined On And Off Peak Supplies

With this arrangement the dwelling has a single supply to the consumer unit from the meter and the whole dwelling goes off-peak or on-peak when the tariff changes at the meter. In this case a single channel clock will need to be fitted in the off peak supply to the PulsaCoil. The off-peak time clock will need to be synchronised with the tariff times set on the meter and be rated for at least 3kW at 230V.

Although the PulsaCoil Stainless appliance is primarily designed to operate with an off peak supply it will also operate quite successfully if it is only supplied with an on peak supply. However, this will substantially increase the running costs of the appliance and should only be considered if an off peak supply is not available.

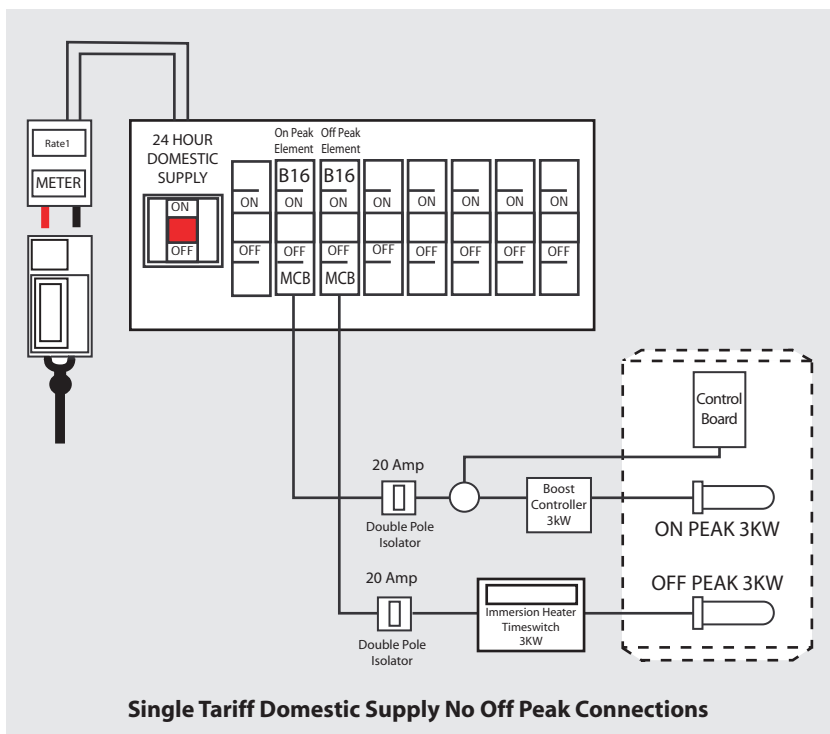

Wiring The PulsaCoil Stainless When Only An On Peak Supply Is Available

With this arrangement the dwelling has no off-peak tariff available. We recommend that a boost controller and immersion heater time switch are fitted.

This will prevent the system being constantly heated but leaving a boost facility available.

To allow the appliance to operate successfully with on peak only supplies, two separate 16A 230V 50Hz supplies MUST be provided with one wired into the on peak connections in the normal way and the other wired into the off peak connections.

In all cases the two switches/isolators must be clearly labelled for the householders use.

INSTALLATION

Feed And Open Vent Pipe

All PulsaCoils are supplied with a header tank. The 150 & 180 sizes are supplied with the circular version. The 210 size is supplied with a cuboid version. The circular version is designed to be fitted on top of the PulsaCoil; the cuboid version should be fitted on a shelf above the unit. The shelf is not supplied.

If it is necessary to locate the cistern in the roof space (or on a higher floor) the cold feed/open vent pipework assembly (as supplied) should be used to connect to the top up cistern and pipework site run by the installer to connect this to the appliance.

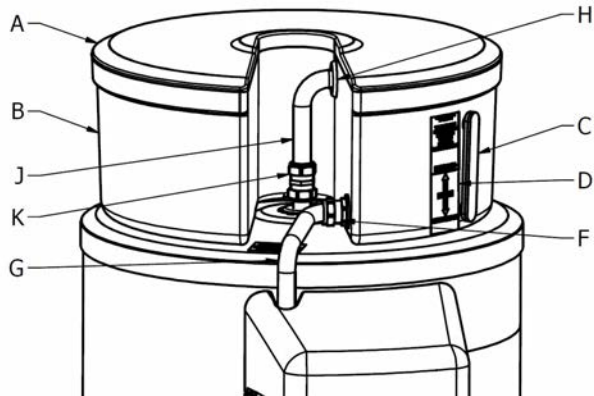

- A Tank Lid
- B Circular feed and expansion tank
- C Water level Sight glass
- D Header tank filling instruction label
- F 22mm tank connector
- G Bent cold feed pipe
- H Vent Pipe Grommet
- J Vent pipe
- K 22mm compression Vent pipe coupling

Please note a drain valve is supplied loose in the header tank kit

In order to prevent frost damage; please ensure that all pipe work run through non heated areas of the building is insulated. **Combined Feed And Open Pipe Arrangements Must Not Be Used.**

No valves should be fitted in the safety open vent which must be a minimum of 22mm copper pipe or equivalent throughout its length.



INSTALLATION

Auto Fill (Float Operated Valve) Header Tank

The cuboid tank is suitable for the fitting of a float operated valve (ball valve). The ball valve is not supplied with the cuboid tank. Please fit a servicing valve on the mains cold water supply to the ball valve, if the auto filling method is being used.

If the auto filling method is being used, an overflow/warning pipe must be provided. This must be continuously sloping away from the header tank, be fitted to discharge clear of the building and be sited so that any overflow can be easily observed. It shall also be installed in a size and material suitable for use with heating feed and expansion cisterns in accordance with BS 5449 (e.g. 22mm copper) and should not have any other connections to it.

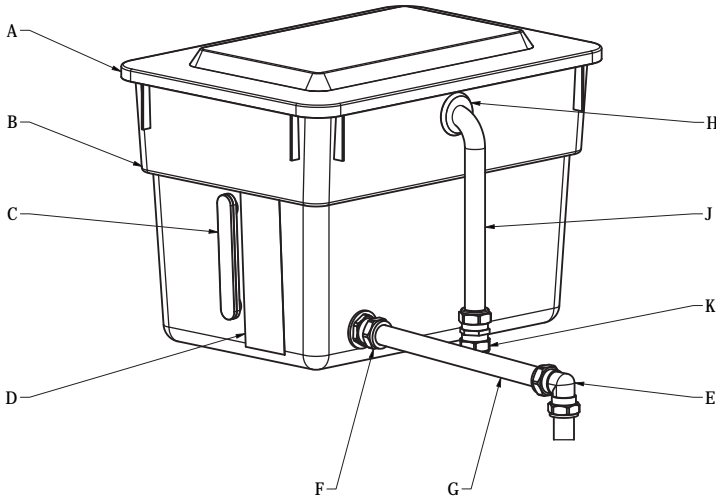

- A Tank Lid
- B Cuboid feed and expansion tank
- C Water level Sight glass
- D Header tank filling instruction label
- E 22mm compression cold feed Elbow
- F 22mm tank connector
- G Straight cold feed pipe
- H Vent Pipe Grommet
- J Vent pipe
- K 22mm compression Vent pipe coupling

Please note a drain valve is supplied loose in the header tank kit

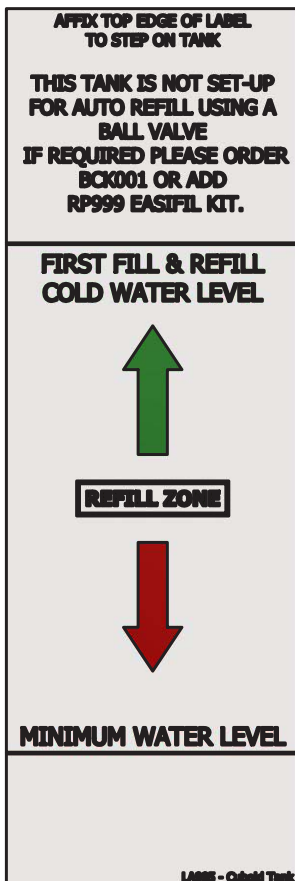

INSTALLATION

Manual Filling of Header Tank

Manual filling of the header tank can be done by using a temporary hose connection supplied from any cold water tap. Using a jug to carry water to the tank. Alternatively, a filling loop (isolator, hose and double check valve) may be fitted to the header tank. If the filling loop method is used, then we recommend the use of a push operated self closing tap; this will prevent accidental overfilling.

The store may fill more slowly than the feed tank. It is important to check the water level again in the cistern after commissioning.

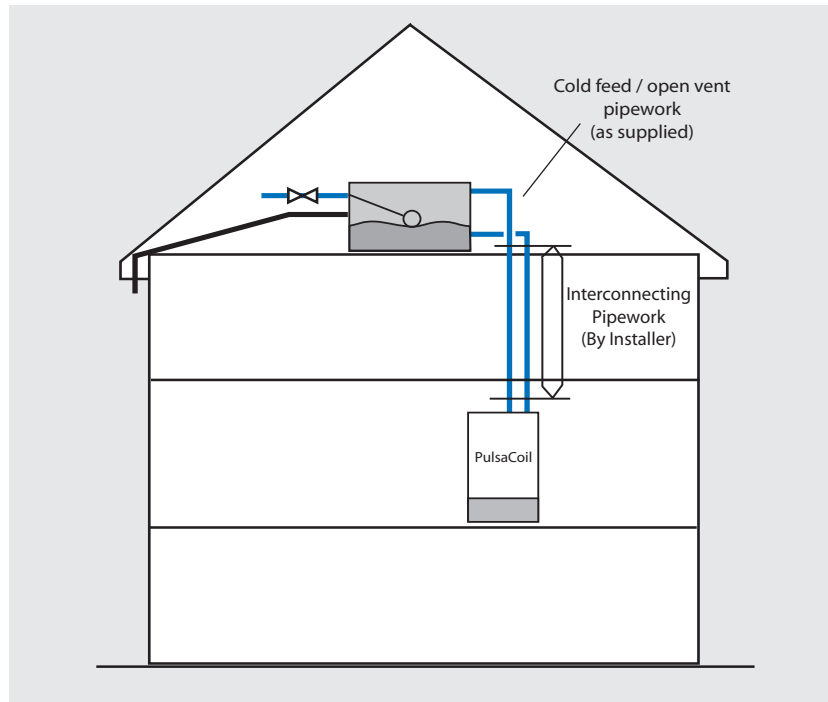

COMMISSIONING

Open the incoming stop valve and fill the domestic mains cold and hot water systems including the PulsaCoil Stainless appliance.

Check the water level in the top up cistern and if a ballvalve is fitted adjust if necessary.

The immersion heater is fitted into the thermal store cylinder using an 'O' ring. After the unit is filled with water check for leaks to determine if the 'O' ring has sealed, and tighten carefully using the appropriate tool. To prevent damage to the 'O' ring do not use excessive force tighten the immersion heater.

Check the whole of the domestic hot and cold distribution systems for leaks. Fully flush and if necessary chlorinate the hot and cold water system in accordance with the recommendations in the Water Regulations and BS EN 806:1-5: BS EN 8558:2011.

Please note that the whole of the domestic hot and cold water systems including the appliance must be adequately flushed after chlorination. Failure to do this can cause damage to the plate heat exchanger/immersion heaters etc. If there are any doubts regarding this or the quality of the water being used to fill the PulsaCoil appliance an inhibitor such as Fernox MBI or Sentinel X100 should be added to the appliance when filling in line with the manufacturers instruction for these products.

Check that the top up tank is filled up to the water level shown on the label. If it is a manual fill model, this is **most important**.

If a ballvalve is provided, turn down the servicing valve once the system is finally filled to the point where the warning/overflow pipe will cope with the discharge arising from a ballvalve failure.

If an overflow is not provided ensure the temporary filling hose is isolated and removed from its connection to the cold water supply.

It is essential that all systems function properly for optimum performance.

To achieve this the flow rate from each tap should be checked and a suitable number of taps run simultaneously to check the impact of this on the flow rate at individual taps. **We recommend that flow regulators are provided for each tap/terminal fitting to ensure that the available flow is shared evenly - See Appendix A for further details.**

Commissioning the PulsaCoil Control System

It can be checked that the boost immersion heater is drawing current by use of a clamp meter on the live supply when boost is active or by interrogating the printed circuit control board in accordance with the instructions in the fault finding section of this manual.

If an off peak supply is available at the time the appliance is switched on. Its operation can be checked with a clamp meter as described above.

If the appliance has been connected with the polarity incorrect it will not operate at all.

See the fault finding section of the manual for further details.

Run a tap and using a digital thermometer check that the temperature of the hot water is about 52°C. This temperature is factory set and is independent of the store temperature assuming the store is above 55°C and typical hot water flow rates of 6-15l/min are being drawn.

At the time of commissioning, complete all relevant sections of the Benchmark Checklist located on the inside back pages of this document. This must be completed during commissioning and left with the product to meet the Warranty conditions offered by Gledhill.

Basic pump operation testing

In order to confirm that the pump is operational, and that all air has been cleared from the pump circuit pipe work, including the PHE. Perform the following actions.

1. Ensure that the unit is full of water
2. Ensure that the primary pipework to the PHE and the PHE itself are bled of air
3. Open hot water tap
4. The pump should then run and hot water will be delivered through the tap

COMMISSIONING

Important Do's and Don'ts

1. **DO** check the incoming mains water pressure. The preferred range of mains pressure is 2 -3 bar.
2. **DO** check the flow rate of the incoming cold water main is adequate to meet the maximum hot and cold water simultaneous demands.
3. **DO** check that all connections are in accordance with the labelling on the thermal store.
4. **DO** check the water level is correctly set in the top up cistern when cold and if fitted that there is no overflow when the appliance is up to temperature.
5. **DO** check that the control thermostats switch the immersion heaters off at the correct set point i.e. approx 75°C.
6. **DO** insulate any exposed hot water pipework in the PulsaCoil cupboard.
7. If the ballvalve in the F & E cistern is permanently connected to the mains cold water supply **DO** plumb the overflow/warning pipe in a 20mm internal diameter pipe and ensure it discharges in a conspicuous external position. Use a material which is suitable for use with heating F & E cisterns in accordance with BS 5449 (such as copper).
8. Once the appliance is filled and commissioned **DO** leave the electricity switched on to the appliance (for further information, see text on page 4).
9. **DO** ensure that the functioning and control of the system is explained to the occupant.
10. **DON'T** place any clothing or other combustible materials against or on top of this appliance.

SERVICING AND MAINTENANCE

	Description	Stock Code
1	PHE pump PWM	XB530
2	Plate heat exchanger (24 Plate)	GT017
3	Pump isolating valve - outlet (90° valve)	GT135
4	Immersion heater 3kW	SH015
5	Stat 75°C overheat (manual reset)	SH016
6	Main PCB controller	XB111
7	Cold water sensor	GT198
8	Y strainer	XB314
9	Flow sensor	XB095
10	Scale inhibitor	XB153
11	Control thermostat	XC010

Note

When ordering the pump isolating valve for a 150 litre model, please note it will come complete with the check valve. If used for the top connection, remove this component.

SERVICING AND MAINTENANCE

Annual Servicing

No annual servicing of the PulsaCoil Stainless is necessary.

However, if required, the operation of the controls and a hot water performance test can be carried out to prove the appliance is working satisfactorily and within its specification.

If it is decided to carry out the above tests the water level in the top cistern should also be checked and if necessary topped up.

Changing Components

Free of charge replacements for any faulty components are available from Gledhill during the in-warranty period on return of the faulty part (normally 12 months).

After this, spares can be obtained direct from Gledhill Spares or through any of the larger plumbers merchants/specialist heating spares suppliers.

Help and advice is also available from the Technical Helpline on 01253 474584.

However, all components are readily accessible and can be changed quickly and easily by the installer using common plumbing/electrical practice.

Note: All maintenance work on the PulsaCoil appliance must be carried out by a competent trades person.

Note:

The pump is a PWM 2 pump. It has 2 cables, one 3 core power cable and one 2 core signal cable. These cables are part of the control box.

SERVICING AND MAINTENANCE

Circulating fluid in thermal store pipework

- The PulsaCoil Stainless and the thermal store pipework must have completed filling prior to switching the electricity supply to the PWM controller PCB. If there is no water in these pipes then there may be significant wear on the PWM pump.
- This can be confirmed by
 - Checking the thermal store pipework servicing valves are open
 - Loosening the connection points on the thermal store pipework in a systematic manner and checking for water presence.
 - Confirming that the feed and expansion tank has completed filling and the servicing valve is open.

Cold mains water supply to plate heat exchanger and hot water taps

- Confirm that the CW mains stop valve is open
- Open all HW taps and confirm that the water runs freely and that any air is bled from the DHW system
- Determine the maximum flow rate obtained and record
- 15l/min for all PulsaCoil products currently limited with a flow restrictor
- If flow rate not as expected determine the cause and rectify
 - clean inline strainer
 - check the flow restrictor is present and not blocked. It is located in the top of the inline strainer

Power on

- Switch on the Local fuse spur and observe the PWM pump
- The green LED will flash showing the pump has a power supply and is in standby mode.
- Open a HW tap and observe the PWM pump
- The green LED will be constantly lit showing the pump has a power supply and is running to generate HW

NOTE: -The thermal store will only produce hot water when it is hot enough. A mid 40°C thermal store temperature will provide some hot water, higher thermal store temperatures will provide more.

Inline scale inhibitor (if fitted)

- Check power supply
- PWM Controller PCB supplies a maximum of 12vDC/300mA to the Scale inhibition board. (From J3)
- Check dip switches set correctly
- The correct settings for tube diameter 22mm is switch no. 3 on.
- Switch no. 4 can be either on or off.
- If the switch no. 4 is turned on the output electromagnetic field is generated harmoniously otherwise the field is generated inharmoniously.

SERVICING AND MAINTENANCE

Test Equipment

The initial assumption in this procedure is that the plumbing and water supply is working effectively. If in doubt please confirm and refer to the end of this section for advice on specific components.

A multi meter, a weir gauge and a thermometer will be required to confirm that all the components are working effectively.

The PWM controller PCB manufacturer suggests "Fluke 87 TRUE RMS Multi meter" as a suitable product. This will be able to measure;

- the frequency output from the Board to the pump
- the Duty cycle % output from the Board to the pump

Connection numbering

For reference the connections to the PCB are numbered below for

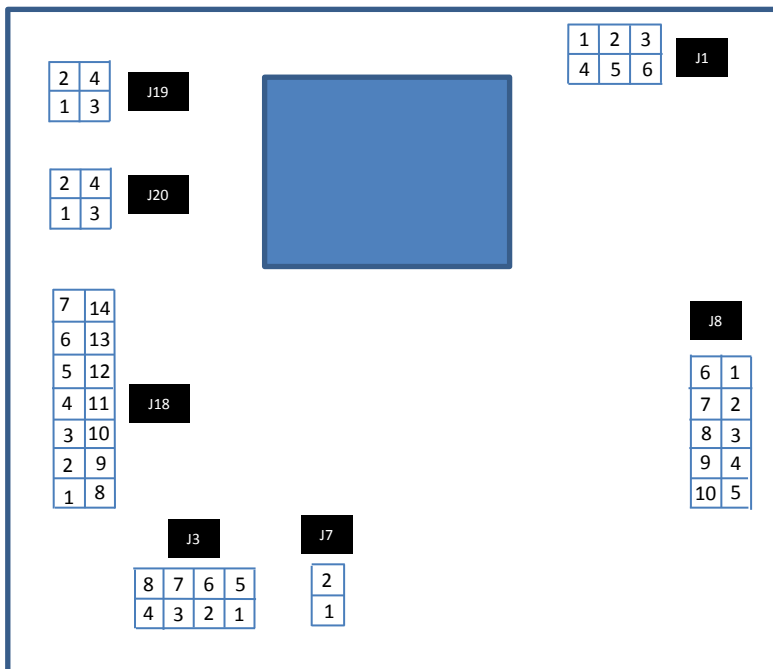

Logical sequence;

- check electrical connections fault finding section on page 23 first to ensure your own safety. This section will potentially identify any short circuited components and/or wiring faults that need to be rectified before continuing to work on the appliance.
- check that the correct information is being supplied to the board. This section will identify if any sensors are faulty or out of tolerance. These will need to be replaced before continuing
- check that the overheat link is present
- check that the outputs to the board are being generated. If at this stage the board does not provide the correct outputs then potentially the board should be replaced
- check the pump electrical circuit

SERVICING AND MAINTENANCE

Electrical power connections

Reference schematic opposite	Check procedure
Power supply to PWM Controller PCB	Electrically isolate power supply at fused spur switch and remove fuse.
	Earth continuity test (dead test) – to ensure that the appliance is earthed
	Mains voltage test (dead test) - to ensure that the appliance is isolated
	Resistance to earth (dead test) – to ensure that the wiring insulation to the product is intact
	Short circuit test (dead test) – to ensure that no components in the products circuit have a short circuit
	Visually inspect wiring is correct as per fig 4.3
	Connect supply
	Polarity test (live test) - to ensure that the live is connector to the live etc <ul style="list-style-type: none"> • Check 230V ac across L1 to Earth • Check 230V ac across L1 to N • Check for 0 to 15V ac N to earth
	Reference to “Boilerfault finder.com” gives clear instructions to on how to perform these tests. (Menu options 1st. Boiler Fault finder 2nd. Electrical safety checks).

Check inputs to the PWM Controller PCB

Reference schematic opposite	Check procedure
CW temperature sensor	Power off
	Disconnect J18
	Measure and record the resistance across terminals 6 and 13
	Measure the cold water inlet temperature
	Compare the resistance measured with chart “Tasseron NTC 12k thermistor”
	The reading should make sense taking measurement conditions into consideration
HW temperature sensor	Power off
	Disconnect J18
	Measure and record the resistance across terminals 7 and 14
	Measure the Hot water temperature
	Compare the resistance measured with chart “HUBA combined flow sensor and NTC 10k thermistor”
	The reading should make sense taking measurement conditions into consideration
Flow sensor	Power on Sensor required a power supply 5 VDC
	Open a HW tap and set to a flow rate.
	Measure and record the frequency across terminals 1 and 12
	Compare the frequency measured with chart “flow rate determination”
	The reading should make sense taking measurement conditions into consideration

SERVICING AND MAINTENANCE

Check pump electrical circuits

LED	Meaning	Diagnosis	Cause	Remedy
Lights green	Normal running	Pump runs according PWM input	Normal operation	n/a
Blinks red/ green	Abnormal running mode -pump stopped but still functional	The pump has stopped due to external failure Pump restarts by itself after the fault has disappeared	Under voltage $U < 160\text{ V}$ or Over voltage $U > 253\text{ V}$	Check voltage supply $195\text{ V} < U < 253\text{ V}$
			Pump overheating: temperature inside motor too high	Check water and ambient temperature
			Over speed: the pump rotor is driven by an external flow above the maximum allowed value	Ensure that there is no other external flow (other pump running) on system
			Over current: the stator winding is in short circuit due to water	Check for leakage application on application
			Overload of motor: friction due to particles and/or impeller blocked with debris	Check installation water quality, clean system if debris
Blinks red	Pump out of function	Pump stopped (blocked)	Blockage: the pumps is fully blocked due to debris in system	Check for blockage. Turn ON/OFF to reset the pump by unplugging the power supply
			Faulty electronic module and/or faulty motor	If the pumps still blinking red after a power reset then replace the pump
LED off	No power supply	No voltage on electronics	Pump is not connected to power supply	Check cable connection
			LED is damaged	Check if pump is running
			Electronics are damaged	Replace pump

Check plumbing components

CW In line filter	Isolate the CW mains supply at the servicing valve
	Open HW taps to relieve the pressure
	Undo securing nut ensuring that any remaining water is collected
	Remove filter and clean it
	The flow regulator can be checked at the same time by removing the upper pipe section.
Thermal store return check valve + return servicing valve	Isolate both servicing valves
	Drain water from the section between the servicing valves
	Remove the bottom pipe section
	Check for free movement of the check valve incorporated in the body. Remove and replace if the check valve sticks.

SERVICING AND MAINTENANCE

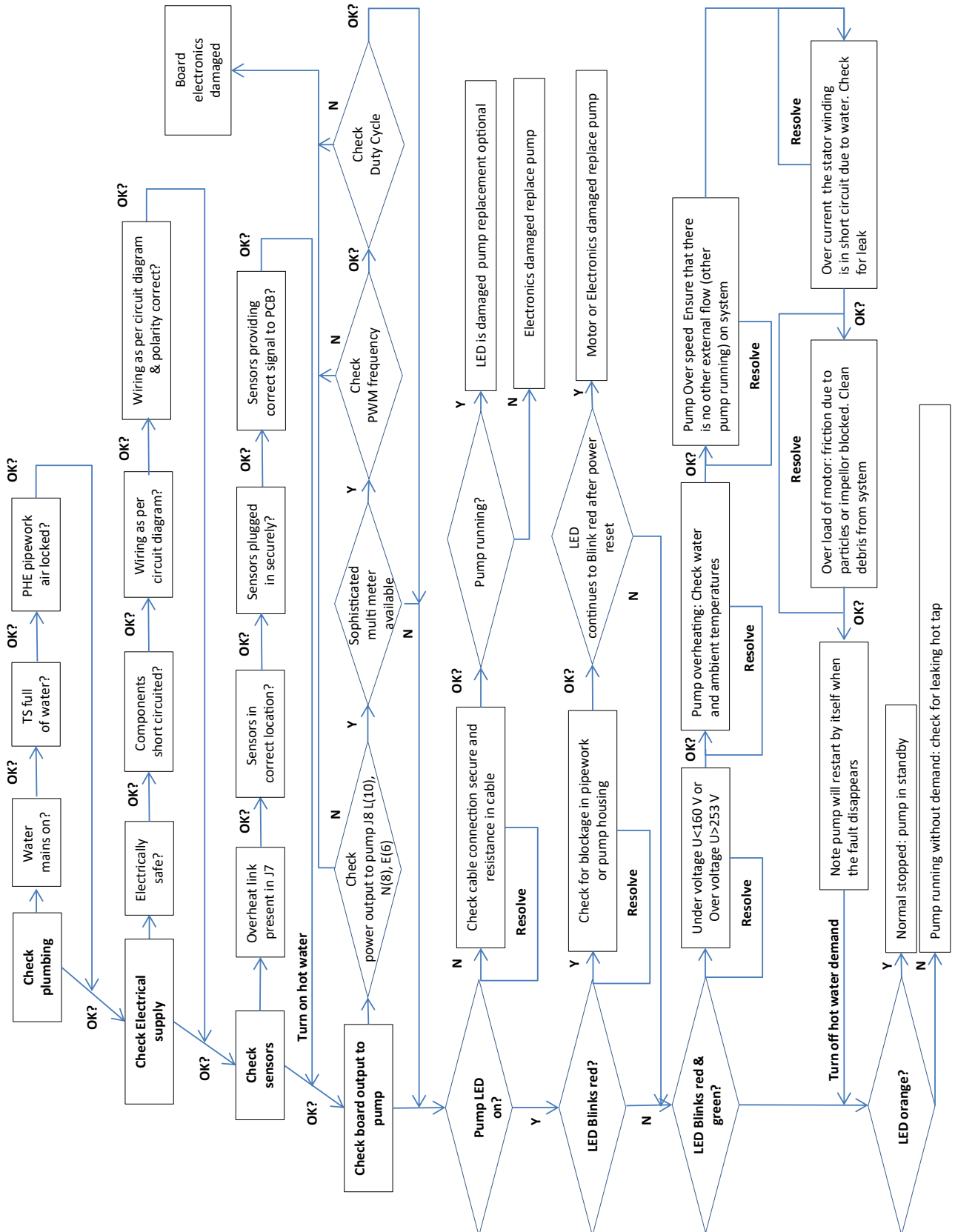

APPENDIX

Water Savings

Water Related Costs Can Be Reduced By Good Plumbing Practice

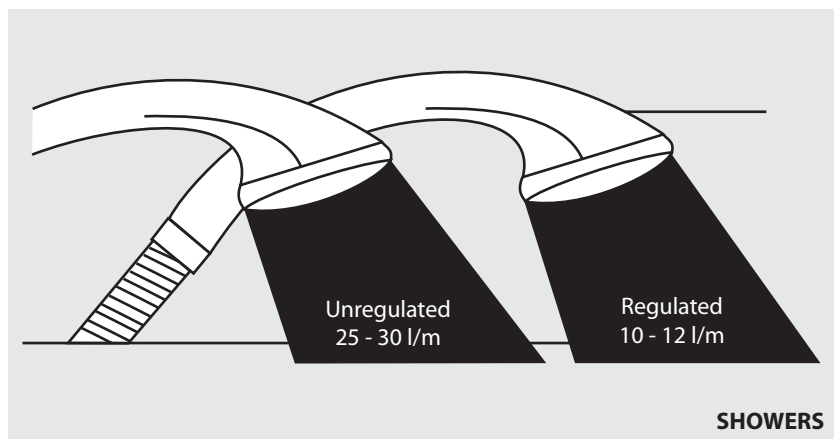
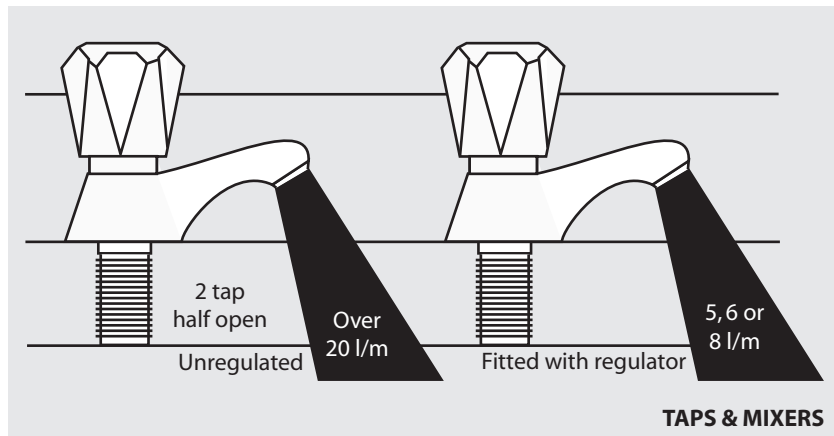

Vast quantities of water are needlessly run off to waste due to Taps, Mixers and Showers discharging flow rates far in excess of the rates required for them to perform their duties.

The contrasting flow rates shown on this leaflet clearly illustrate the savings that can be made whilst still providing a good performance.

British made Aquaflow Regulators provide constant flow rates by automatically compensating for supply pressure changes between 1 bar & 10 bars.

To facilitate installation into the wide range of plumbing equipment which is encountered in the U.K, Four Fixing Options are available:-

Options For Showers

1. MXF "DW" Range - For fitting behind Fixed Shower Heads or onto Flexible Hoses for Handshowers (preferably onto the inlet end when lightweight hoses are used).
2. Compression Fitting Range. "In Line" regulators as in Option 4 for Taps & Mixers.

Information by courtesy of
AQUAFLOW REGULATORS LTD

Haywood House, 40 New Road, Stourbridge, West Midlands DY8 1PA
TELEPHONE (01384) 442611 FAX: (01384) 442612

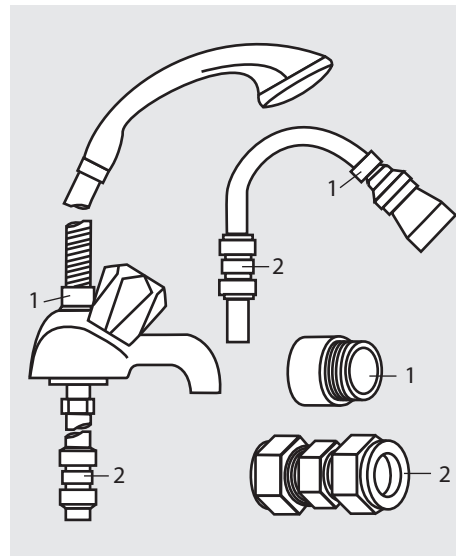

4 Fixing Options For Taps & Mixers

1. MK Range - Combined Regulators & Aerator for screwing onto Taps & Mixers with internal or external threads on their noses. Anti Vandal models also available.
2. MR05-T Range - Internal Regulators. Push-fit into Tap or Mixer seats. Produced in three sizes - 12.5mm (BS1010), 12mm & 10mm, Flangeless models also available for Taps with Low Lift washers.
3. MXF Standard Range - Screw on tail models for Taps & Mixers. Fix onto the tails before fitting the tap connectors. Available in 3/8", 1/2", 3/4" and 1" BSP.
4. Compression Fitting Range - "In Line" regulators housed in 15mm & 22mm CXC Couplers & Isolating Valves. "UKWFBS listed by the Water Research Centre. Isolation valves available for slotted screwdriver operation or with coloured plastic handles. Now available also in plastic bodied push-fit couplers & valves.

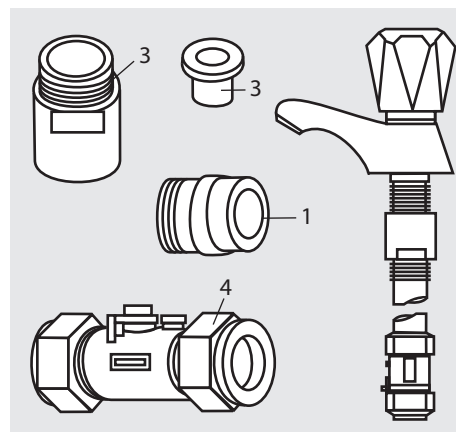



2 Inhibitor (Corrosion & scale protection of primary heating circuit)

On filling the heating system and before the boiler is fired up, it is important to ensure the system water is treated with a suitable corrosion inhibitor, in accordance with the boiler manufacturer's instructions.

Since the concentration of inhibitor present in a system can become diluted, for a number of different reasons, the system should be checked annually and re-treated as required, or after every full or partial drain-down. A water treatment manufacturer's test kit may be used to check the correct concentration of inhibitor in the system.

Where recommended by a boiler manufacturer, a 'physical corrosion protection device' may be fitted in the primary pipework in accordance with the boiler manufacturer's instructions.

The Benchmark checklist should be completed indicating the date and details of any of the above products added and a permanent label should be fixed to the system in a prominent location.

3 Scale protection (Domestic hot water service)

Where a combi boiler and/or a hot water storage vessel is installed in areas where the mains water can exceed 200ppm Total Hardness (as defined by BS 7593: 1993 Table 2) a scale reduction device should be installed, in accordance with the boiler manufacturer's instructions.

The levels of water hardness may be measured using a water hardness test kit.

BUILDING REGULATIONS

Completion of the Benchmark checklist requires that the 'competent person' undertaking the installation and commissioning provide information relating to Cleaning, Inhibitor and Scale Protection. This will demonstrate that the work complies with the requirements of the appropriate Building Regulations.

This Guidance Note is produced on behalf of its members by the Central Heating Information Council. For a full list of members visit www.centralheating.co.uk and for further advice on water treatment contact the following members:

 Culligan  Sentinel  Ferox  Salamander Engineering  Scalmaster

Heating & Hotwater Information Council, 36 Holly Walk, Leamington Spa,
Warwickshire CV32 4LY Tel: 0845 600 2200 Fax: 01926 423284
www.centralheating.co.uk



Benchmark is managed by The Heating & Hotwater Information Council

Gledhill (Building Products) Ltd

AMD. APRIL 2018

CONDITIONS OF SALE & GUARANTEE TERMS

1. Gledhill (Building Products) Ltd ("We" or "Gledhills") only do business upon the Conditions which appear below and no other. Unless we so agree in writing these Conditions shall apply in full to any supply of goods by us to the exclusion of any Conditions or terms sought to be imposed by any purchaser. These Conditions of Sale and Warranty Terms override those which are contained on the Invoice Forms and all Sales are now subject to these Conditions of Sale and Warranty terms only.

2. PRICE

Once an order or call off has been accepted the price will be held for three months **but if delivery is extended beyond that period at the customer's request, then we reserve the right to amend the price when necessary.** The company reviews its pricing annually to adjust for changes in our cost base. We reserve the right to alter prices at any time for severe movements in raw materials (mainly copper and steel). If there is to be a change we will give customers at least four weeks notice but anything delivered after that date will be at the revised price. An order may not be cancelled or varied after acceptance without the written consent of the company. Such cancellation or variation shall be subject to such reasonable charges as may be appropriate.

3. SPECIFICATION

The goods are supplied in accordance with the Specifications (if any) submitted to the Purchaser and any additions and alterations shall be the subject of an extra charge. Any goods not so specified shall be in accordance with our printed literature or the literature of any of our component suppliers (subject to any modifications made since publication). If we adopt any changes in construction or design of the goods, or in the specification printed in our literature, the Purchaser shall accept the goods so changed in fulfilment of the order.

4. PAYMENT

The buyer shall make payment in full within thirty days from the end of the month in which the invoice is dated. If we receive payment in full on or before the due date we will allow an appropriate settlement discount except where we have quoted a special net price. If payment is not received in full on or before the due date we shall be entitled in addition to the invoice price to:

- (i) payment of a sum equal to any increase in the copper price supplement applicable to the particular goods sold between the date of receipt of order and the date of receipt of payment in full; and
- (ii) interest on any part of the invoice price unpaid after the due date at the rate of 3% per annum over the base rate for the time being of HSBC Bank plc.

5. TIME

We give estimates of delivery dates in good faith and time of delivery is not nor shall be made of the essence of any contract nor shall we be liable for any loss or damage occasioned by delay in delivery.

6. DELIVERY

Standard delivery is free of charge on normal lead times to mainland UK. We reserve the right to make delivery of goods contained in one order by more than one consignment and at different times. Where a period is agreed for delivery and such period is not extended by our Agreement, the Purchaser shall take delivery within that period. If the Purchaser fails to take delivery, we shall be entitled at the Purchaser's risk and expense to store the goods at the Purchaser's premises or elsewhere and to demand payment as if they had been despatched. Off loading at point of delivery shall be the responsibility of and be undertaken by the Purchaser.

7. SHORTAGES OR DAMAGE

Goods must be inspected before signature of delivery note and any damage, shortage or discrepancy noted on the delivery note and the goods returned on the same vehicle. The buyer must also give us immediate written notice of the damage, shortage or discrepancy so that we may prompt investigation.

8. RETURN OF GOODS

Goods may not be returned to the Company except by prior written permission of an authorised officer of the Company and such return shall be subject to payment by the Purchaser of handling and re-stocking charges, transport and all other costs incurred by the Company.

9. COMPANY LIABILITY AND GUARANTEE

9.1. Subject to the terms of these Conditions of Sale and Guarantee Terms Gledhills provide Guarantees in respect of specific products as set out in this clause.

9.2. Each Guarantee is strictly conditional upon the following:-

9.2.1. Complaints must be given to us immediately, before any action is taken, as responsibility cannot be accepted if repairs or renewals are attempted on site without our written approval.

9.2.2. The unit has been installed in accordance with our installation and service instructions and all relevant codes of practice and regulations in force at the time of installation.

9.2.3. All necessary inlet controls and safety valves have been fitted correctly.

9.2.4. The unit has only been used for the storage of potable water supplied from the public mains. The water quality shall be in accordance with European Council Directive 98/83 EC, or revised version at the date of installation, and is not fed with water from a private supply. Particular:

Chloride content:	Max. 200 mg/l
Sulphate content:	Max. 200 mg/l
Combination chloride/sulphate:	Max. 300 mg/l (in total)

9.2.5 Where appropriate the unit has been regularly maintained as detailed in the installation and service instructions

9.2.6. Defects caused by corrosion or scale deposits are not covered by any Guarantee.

9.2.7. Where we agree to rectify any defect we reserve the right to undertake the work on our own premises.

9.2.8. We will not accept any labour charges associated with replacing the unit or parts for any of the following products listed.

9.2.9. If the newly fitted water heater is not in regular use then it must be flushed through with fresh water for at least 15 minutes. Open at least one hot water tap once per week, during a period of at least 4 weeks.

9.3. Guarantees are provided in respect of specified goods supplied by Gledhills as follows:-

(a) Domestic and Commercial Open Vented Cylinders and Tanks.

The storage vessel is guaranteed for ten years and if it proves to be defective either in materials or workmanship, we reserve the right to either repair or supply replacement at our option with the closest substitute in the case of any obsolete product to any address in England, Wales and Scotland (excluding all Scottish Islands).

(b) Domestic Mains Fed Products [Primary Stores]

The storage vessel is guaranteed for five years and if it or any integral pipework as part of the storage vessel assembly proves to be defective either in materials or workmanship, we reserve the right to either repair or supply replacement at our option with the closest substitute in the case of any obsolete product to any address in England, Wales and Scotland (excluding all Scottish Islands).

(c) Unvented Cylinders

Gledhill guarantee the components including controls, valves and electrical parts for two years from the date of purchase. IT SHOULD BE NOTED THAT THE FACTORY FITTED TEMPERATURE AND PRESSURE RELIEF VALVE MUST NOT BE REMOVED OR ALTERED IN ANY WAY OR THE GUARANTEE WILL NOT BE VALID. GLEDHILL WILL NOT BE RESPONSIBLE FOR ANY CONSEQUENTIAL LOSS OR DAMAGE HOWEVER IT IS CAUSED.

The guarantee for the stainless steel vessel is for twenty five years against material defect or manufacturing faults if the original unit is returned to us **AND PROVIDED THAT:**

- (i) It has not been modified, other than by Gledhill.
- (ii) It has not been subjected to wrong or improper use or left uncared for.
- (iii) It has only been used for the storage of potable water supplied from the public mains, max 200mg/litre chloride.
- (iv) It has not been subjected to frost damage.
- (v) The benchmark service record is completed after each annual service.
- (vi) The unit has been serviced annually.
- (vii) Any disinfection has been carried out strictly in accordance with BS6700.

If the stainless steel vessel proves to be defective either in materials or workmanship we reserve the right to either repair or supply replacement at our option with the closest substitute in the case of any obsolete product to any address in England, Wales and Scotland (excluding all Scottish Islands).

ACTION IN THE EVENT OF FAILURE

We will require the return of a cylinder which develops a leak for inspection. If our examination confirms a failure then an appropriate level of credit against the cost of the original cylinder will be issued in line with the terms of our warranty.

Please note:

- Installation must have been carried out by a licensed specialized company (heating contractor or plumber) following the version of installation instructions in force.
- Gledhill or its representative was given the opportunity to check complaints on site immediately after any defect occurred.
- Confirmation exists that the system was commissioned properly and that the system was checked and maintenance was performed annually by a specialised company licensed for this purpose.

(d) Components of our products other than Storage Vessels and Integral Pipework.

We will either extend to the purchaser the same terms of warranty as we are given by the manufacturer of the component or if the manufacturer does not give any warranty, replace free of charge any component which becomes defective within two years after the date of the delivery by us and is returned to us at the purchaser's expense but we shall not meet the cost of removal or shipping or return of the component or any other cost charges or damages incurred by the purchaser.

9.4.

9.4.1. In respect of goods supplied by us and in respect of any installation work carried out by or on our behalf, our entire liability and the purchaser's sole remedies (subject to the Guarantees) shall be as follows:-

(a) We accept liability for death or personal injury to the extent that it results from our negligence or that of our employees

(b) Subject to the other provisions of this clause 9 we accept liability for direct physical damage to tangible property to the extent that such damage is caused by our negligence or that of our employees, agents or subcontractors.

(c) Our total liability to the purchaser over and above any liability to replace under the Guarantees (whether in contract or in tort including negligence) in respect of any one cause of loss or damage claimed to result from any breach of our obligations hereunder, shall be limited to actual money damages which shall not exceed £20,000 provided that such monetary limit shall not apply to any liability on the part of ourselves referred to in paragraph (a) above

(d) Except as provided in paragraph (a) above but otherwise not withstanding any provision herein contained in no event shall we be liable for the following loss or damage howsoever caused and even if foreseeable by us or in our contemplation:-

- (i) economic loss which shall include loss of profits, business revenue, goodwill or anticipated savings

- (ii) damages in respect of special indirect or consequential loss or damage (other than death, personal injury and damage to tangible property)
- (iii) any claim made against the purchaser by any other party (save as expressly provided in paragraph (b) above)
- (e) Except in respect of our liability referred to in paragraph (a) above no claim may be made or action brought (whether in contract or in tort including negligence) by the purchaser in respect of any goods supplied by us more than one year after the date of the invoice for the relevant goods.
- (f) Without prejudice to any other term we shall not be liable for any water damage caused directly or indirectly as a result of any leak or other defect in the goods. We cannot control the conditions of use of the goods or the time or manner or location in which they will be installed and the purchaser agrees to be fully responsible for testing and checking all works which include the goods at all relevant times (up to, including and after commissioning) and for taking all necessary steps to identify any leaks and prevent any damage being caused thereby.
- (g) Nothing in these Conditions shall confer on the purchaser any rights or remedies to which the purchaser would not otherwise be legally entitled

10. LOSS OR INJURY

Notwithstanding any other provision contained herein the purchaser's hereby agree to fully indemnify us against any damages losses costs claims or expenses incurred by us in respect of any claim brought against us by any third party for:-

- (a) any loss injury or damage wholly or partly caused by any goods supplied by us or their use.
- (b) any loss injury or damage wholly or partly caused by the defective installation or substandard workmanship or materials used in the installation of any goods supplied by us.
- (c) any loss injury or damage in any way connected with the performance of this contract.
- (d) any loss resulting from any failure by the purchaser to comply with its obligations under these terms as to install and/or check works correctly.

PROVIDED that this paragraph will not require the purchaser to indemnify us against any liability for our own acts of negligence or those of our employees agents or sub-contractors

FURTHER in the case of goods supplied by us which are re-sold and installed by a third party by the purchaser it will be the sole responsibility of the purchaser to test the goods immediately after their installation to ensure that inter alia they are correctly installed and in proper working order free from leaks and are not likely to cause any loss injury or damage to any person or property.

11. VARIATION OF WARRANTY AND EXCLUSION

Should our warranty and exclusion be unacceptable we are prepared to negotiate for variation in their terms but only on the basis of an increase in the price to allow for any additional liability or risk which may result from the variation. Purchasers are advised to insure against any risk or liability which they may incur and which is not covered by our warranty.

12. ADVICE

Any advice or assistance given by the Company is provided without charge and is in good faith without undertaking, representation or warranty, and we will not accept any liability, whether consequential or compensatory, for advice or assistance given.

13. RISK AND RETENTION OF TITLE

- (a) goods supplied by us shall be at the Purchaser's risk immediately upon delivery to the Purchaser or into custody on the Purchaser's behalf or to the Purchaser's Order. The Purchaser shall effect adequate insurance of the goods against all risks to the full invoice value of the goods, such insurance to be effective from the time of delivery until property in the goods shall pass to the Purchaser as hereinafter provided.
- (b) property in the goods supplied hereunder will pass to the Purchaser when full payment has been made by the Purchaser to us for :-
 - (i) the goods of the subject of this contract.
 - (ii) all other goods the subject to of any other contract between the Purchaser and us which, at the time of payment of the full price of the goods sold under this contract, have been delivered to the Purchaser but not paid for in full.
- (c) until property in the goods supplied hereunder passes to the Purchaser in accordance with paragraph (2) above.
 - (i) the Purchaser shall hold the goods in a fiduciary capacity for us and shall store the same separately from any other goods in the Purchaser's possession and in a manner which enables them to be identified as our goods.
 - (ii) the Purchaser shall immediately return the goods to us should our authorised representative so request. All the necessary incidents associated with a fiduciary relationship shall apply.
- (d) the Purchaser's right to possess the goods shall cease forthwith upon the happening of any of the following events, namely :-
 - (i) if the Purchaser fails to make payment in full for the goods within the time stipulated in clause 4 hereof.
 - (ii) if the Purchaser, not being a company, commits any act of bankruptcy, makes a proposal to his or her creditors for a compromise or does anything which would entitle a petition for a Bankruptcy Order to be presented.
 - (iii) if the Purchaser, being a company, does anything or fails to do anything which would entitle an administrator or an administrative receiver or a receiver to take possession of any assets or which would entitle any person to present a petition for winding up or to apply for an administration order.
- (e) the Purchaser hereby grants to us an irrevocable licence to enter at any time any vehicle or premises owned or occupied by the Purchaser or in the possession of the Purchaser for the purposes of repossessing and recovering any such goods the property in which has remained in us under paragraph (2) above. We shall not be responsible for and the Purchaser will indemnify us against liability in respect of damage caused to any vehicle or premises in such repossession and removal being damaged which it was not reasonably practicable to avoid.
- (f) notwithstanding paragraph (3) hereof and subject to paragraph (7) hereof, the Purchaser shall be permitted to sell the goods to third parties in the normal course of business. In this respect the Purchaser shall act in the capacity of our commission agent and the proceeds of such sale :-
 - (i) shall be held in trust for us in a manner which enables such proceeds to be identified as such, and;
 - (ii) shall not be mixed with other monies nor paid into an overdrawn bank account.

We, as principal, shall remunerate the Purchaser as commission agent a commission depending upon the surplus which the Purchaser can obtain over and above the sum, stipulated in this contract of supply which will satisfy us.
- (g) in the event that the Purchaser shall sell any of the goods pursuant to clause (6) hereof, the Purchaser shall forthwith inform us in writing of such sale and of the identity and address of the third party to whom the goods

have been sold.

- (h) if, before property in the goods passes to the Purchaser under paragraph (2) above the goods are or become affixed to any land or building owned by the Purchaser it is hereby agreed and declared that such affixation shall not have the effect of passing property in the goods to the Purchaser. Furthermore if, before property in the goods shall pass to the Purchaser under paragraph (2) hereof, the goods are or become affixed to any land or building (whether or not owned by the Purchaser), the Purchaser shall:-
 - (i) ensure that the goods are capable of being removed without material injury to such land or building.
 - (ii) take all necessary steps to prevent title to the goods from passing to the landlord of such land or building.
 - (iii) forthwith inform us in writing of such affixation and of the address of the land or building concerned.

The Purchaser warrants to repair and make good any damage caused by the affixation of the goods to or their removal from any land or building and to indemnify us against all loss damage or liability we may incur or sustain as a result of affixation or removal.

 - (i) in the event that, before property in the goods has passed to the Purchaser under paragraph (2) hereof, the goods or any of them are lost, stolen, damaged or destroyed :-
 - (ii) the Purchaser shall forthwith inform us in writing of the fact and circumstances of such loss, theft, damage or destruction.
 - (iii) the Purchaser shall assign to us the benefit of any insurance claim in respect of the goods so lost, stolen, damaged or destroyed.

14. NON-PAYMENT

If the Purchaser shall fail to make full payment for the goods supplied hereunder within the time stipulated in clause 4 hereof or be in default of payment for any other reason then, without prejudice to any of our other rights hereunder, we shall be entitled to stop all deliveries of goods and materials to the Purchaser, including deliveries or further deliveries of goods under this contract. In addition we shall be entitled to terminate all outstanding orders.

15. VALUE ADDED TAX

All prices quoted are exclusive of Value Added Tax which will be charged at the rate ruling at the date of despatch of invoice.

16. TRADE SALES ONLY

We are only prepared to deal with those who are not consumers within the terms of the Unfair Contract Terms Act 1977, the Sale of Goods Act 1979 and the Supply of Goods and Services Act 1982. Accordingly any person who purchases from us shall be deemed to have represented that he is not a consumer by so purchasing.

17. JURISDICTION

The agreement is subject to English law for products delivered in England and Scottish law for products delivered in Scotland and any dispute hereunder shall be settled in accordance therewith dependent upon the location.

18. PRODUCT DEVELOPMENT

Gledhill have a policy of continuous product development and may introduce product modifications from time to time.

MAINS PRESSURE HOT WATER STORAGE SYSTEM COMMISSIONING CHECKLIST

This Commissioning Checklist is to be completed in full by the competent person who commissioned the storage system as a means of demonstrating compliance with the appropriate Building Regulations and then handed to the customer to keep for future reference.

Failure to install and commission this equipment to the manufacturer's instructions may invalidate the warranty but does not affect statutory rights.

Customer name:		Telephone number:	
Address:			
Cylinder Make and Model			
Cylinder Serial Number			
Commissioned by (PRINT NAME):		Registered Operative ID Number	
Company name:		Telephone number:	
Company address:			
		Commissioning date:	
To be completed by the customer on receipt of a Building Regulations Compliance Certificate*:			
Building Regulations Notification Number (if applicable)			
ALL SYSTEMS PRIMARY SETTINGS (indirect heating only)			
Is the primary circuit a sealed or open vented system?		Sealed	Open
What is the maximum primary flow temperature?			°C
ALL SYSTEMS			
What is the incoming static cold water pressure at the inlet to the system?			bar
Has a strainer been cleaned of installation debris (if fitted)?		Yes	No
Is the installation in a hard water area (above 200ppm)?		Yes	No
If yes, has a water scale reducer been fitted?		Yes	No
What type of scale reducer has been fitted?			
What is the hot water thermostat set temperature?			°C
What is the maximum hot water flow rate at set thermostat temperature (measured at high flow outlet)?			l/min
Time and temperature controls have been fitted in compliance with Part L of the Building Regulations?		Yes	
Type of control system (if applicable)		Y Plan	S Plan Other
Is the cylinder solar (or other renewable) compatible?		Yes	No
What is the hot water temperature at the nearest outlet?			°C
All appropriate pipes have been insulated up to 1 metre or the point where they become concealed		Yes	
UNVENTED SYSTEMS ONLY			
Where is the pressure reducing valve situated (if fitted)?			
What is the pressure reducing valve setting?			bar
Has a combined temperature and pressure relief valve and expansion valve been fitted and discharge tested?		Yes	No
The tundish and discharge pipework have been connected and terminated to Part G of the Building Regulations		Yes	
Are all energy sources fitted with a cut out device?		Yes	No
Has the expansion vessel or internal air space been checked?		Yes	No
THERMAL STORES ONLY			
What store temperature is achievable?			°C
What is the maximum hot water temperature?			°C
ALL INSTALLATIONS			
The hot water system complies with the appropriate Building Regulations		Yes	
The system has been installed and commissioned in accordance with the manufacturer's instructions		Yes	
The system controls have been demonstrated to and understood by the customer		Yes	
The manufacturer's literature, including Benchmark Checklist and Service Record, has been explained and left with the customer		Yes	
Commissioning Engineer's Signature			
Customer's Signature			
(To confirm satisfactory demonstration and receipt of manufacturer's literature)			

*All installations in England and Wales must be notified to Local Authority Building Control (LABC) either directly or through a Competent Persons Scheme. A Building Regulations Compliance Certificate will then be issued to the customer.



While this Checklist can be used for any installation covered by its description, only appliances manufactured by Scheme Members will be covered by the rules and requirements of the Benchmark Scheme.

SERVICE RECORD

It is recommended that your hot water system is serviced regularly and that the appropriate Service Record is completed.

Service Provider

Before completing the appropriate Service Record below, please ensure you have carried out the service as described in the manufacturer's instructions.

SERVICE 01		Date:	SERVICE 02		Date:
Engineer name:			Engineer name:		
Company name:			Company name:		
Telephone No:			Telephone No:		
Comments:			Comments:		
.....				
.....				
.....				
.....				
Signature			Signature		
SERVICE 03		Date:	SERVICE 04		Date:
Engineer name:			Engineer name:		
Company name:			Company name:		
Telephone No:			Telephone No:		
Comments:			Comments:		
.....				
.....				
.....				
.....				
Signature			Signature		
SERVICE 05		Date:	SERVICE 06		Date:
Engineer name:			Engineer name:		
Company name:			Company name:		
Telephone No:			Telephone No:		
Comments:			Comments:		
.....				
.....				
.....				
.....				
Signature			Signature		
SERVICE 07		Date:	SERVICE 08		Date:
Engineer name:			Engineer name:		
Company name:			Company name:		
Telephone No:			Telephone No:		
Comments:			Comments:		
.....				
.....				
.....				
.....				
Signature			Signature		
SERVICE 09		Date:	SERVICE 10		Date:
Engineer name:			Engineer name:		
Company name:			Company name:		
Telephone No:			Telephone No:		
Comments:			Comments:		
.....				
.....				
.....				
.....				
Signature			Signature		

TO REGISTER

CALL: 08000 420 430

VISIT: WWW.GLEDHILL.NET/CONTACT-US/PRODUCT-REGISTRATION/

FOR TECHNICAL SUPPORT:

01253 474584

FOR ANNUAL SERVICE AND MAINTENANCE:

0800 3800 129

FOR SPARE PARTS:

01253 474412

OR

WWW.GLEDHILL-SPARES.NET



Gledhill Building Products Limited
Sycamore Estate,
Squires Gate,
Blackpool FY4 3RL

T: 01253 474550
enquiries@gledhill.net

WWW.GLEDHILL.NET



Due to a programme of continuous improvement Gledhill Building Products reserve the right to modify products without prior notice. It is advisable to check the product technical detail by using the latest design and installation manuals available from our technical support team or on our website. It is an offence to copy or adapt this document without consent of the owner.